

# 2018-19 DBF Rules

---

## Rules

### Summary:

The AIAA through the Applied Aerodynamics, Aircraft Design, Design Engineering and Flight Test Technical Committees and the AIAA Foundation invites all university students to participate in the Textron Aviation/Raytheon Missile Systems - Student Design, Build, Fly Competition. The contest will provide a real-world aircraft design experience for engineering students by giving them the opportunity to validate their analytic studies.

Student teams will design, fabricate, and demonstrate the flight capabilities of an unmanned, electric powered, radio controlled aircraft that can best meet the specified mission profile. The goal is a balanced design possessing good demonstrated flight handling qualities and practical and affordable manufacturing requirements while providing a high vehicle performance.

To encourage innovation and maintain a fresh design challenge, the design requirements and performance objectives will be updated for each new contest year. The changes will provide new design requirements and opportunities, while allowing for application of technology developed by the teams from prior years.

***Check the rules package carefully as items and approaches that were legal in past years may not be legal for this contest year. Only the contents of this year's Rules package along with the current FAQ and Q&A documents hold bearing on the requirements and/or allowances for the current contest year.***

It is the responsibility of the teams to know and follow all provided rules, the FAQ, and all contest day briefings.

Cash prizes are \$2500 for 1st, \$1500 for 2nd and \$1000 for 3rd place. The winning team may be invited to present their design at an AIAA conference. The team with the best Report Score will receive a \$100 prize from the Design Engineering Technical Committee.

### How to use the Rules Pages

The rules pages are separated out into blocks of material that should help you to quickly and easily find information for which you are looking. In addition, each rules page has a link to download the entire set of rules for the current year.

- **General Information** - This page will go over the basic information of the competition. Information includes team requirements, reports that are required, general schedule of activities, communications, deadlines, and other basic information
- **Schedule** - This page will provide information about deadlines for proposals and design reports. It will also note the date and location of the Flyoff

- **Mission and Vehicle Design** - This page discusses the current year's mission. It notes payload(s) required, types of missions, and number of laps that may be required. It also notes specifications for the current year's aircraft. The aircraft information includes details about fail-safe, structural integrity and inspection, and general aircraft requirements
- **Reports** – This page defines the requirements and scoring criteria for both the Proposal that is submitted with the team entry and the Design Report
- **Scoring** - This page indicates how a team's overall score is calculated. It notes the formula for determining each mission score and overall flight score. It also provides the rubric for reports that are required to be submitted
- **Flyoff Site** - This page will note the date and location of the Flyoff. Specific agenda items for contest days may be noted
- **FAQ** - This page answers questions that asked often by persons that want to compete in the competition.
- **Q&A** -This page answers specific questions about this year's competition.

## General Information

### Team Requirements:

All team members (except for a non-student pilot) must be full time students at an accredited University or College and student members of the AIAA. At least 1/3 of the team members must consist of freshman, sophomores or juniors (below senior year, for non-four year programs). The pilot must be an AMA (Academy of Model Aeronautics) member. Teams may use a non-university member for the pilot if desired. We will provide qualified pilots at the contest on an as-available basis to assist teams who are unable to have their pilot attend.

There is no set requirement for the number of students that must attend the flyoff. It is preferred, but not required, for the team advisor or responsible faculty member to attend.

Team members may be updated/changed at any time during the contest but must always comply with the 1/3 rule. Following the initial team postings at the contest beginning we will make a "One Time" update to the team member lists posted on the website. We will notify teams when the website update change information may be sent, normally in February. Teams wishing a team member list update at that time must submit an updated copy of the contest entry form with all fields fully filled (but only the team member information may be changed).

***Each educational institution may submit one (1) team entry.***

The team members may be changed during the contest period, so schools may use an internal selection process to determine their final design and team members prior to the written report submission and fly-off. For schools with multiple campuses in different cities each campus will be considered as a separate entity.

Two or more schools may combine to submit a single entry.

Schools which already have an entry may not have additional students from their school participate as members of a team from a different (shadow) school.

There is no entry limit this year.

### Past Year Reports:

Winning team design reports from [prior contest](#) years are posted on the contest website as examples. Note that the formatting and content has evolved from one year to the next. Only the rules noted in **Reports** apply for the current year. The top scoring report(s) from this year's contest will be placed on the contest web site for the next year's competition.

### Sponsorship:

Teams may solicit and accept sponsorship in the form of funds or materials and components from commercial organizations. All design, analysis, and fabrication of the contest entry is the sole responsibility of the student team members.

### Communications:

The contest administration will maintain a website containing the latest information regarding the contest schedules, rules, and participating teams. The contest web site is <http://www.aiaadbf.org>

Questions regarding the contest, schedules, or rules interpretation may be sent to the contest administrator by email at: [director@aiaadbf.org](mailto:director@aiaadbf.org)

Questions received prior to the official entry submission date will not be answered directly. Select questions “may” be answered in the FAQ prior to the entry submission date. Official questions and answers received following the entry submission date will be posted on the website **FAQ**.

The DBF Organizing Committee will utilize [Facebook](#) as an additional means of communicating with the teams during the contest weekend only. This will NOT be a means of communicating rules, FAQ's, protests, etc., but only used in case of emergencies, weather delays or contest weekend schedule updates. Additional information will be included in a contest site/ schedule email to be sent out to the registered teams prior to the fly-off.

### **Flight Line and Order:**

A flight order list will be generated and emailed to the teams on the Wednesday prior to the fly-off weekend. Teams will always rotate in this order. The flight order will be repeated continuously.

The flight order list will carry over from Thursday to Friday, Friday to Saturday and Saturday to Sunday at whatever spot in the rotation it leaves off.

Each team’s position in the flight order will be determined from their **written report score**, highest report score goes first.

Report scores will be available following the pilot briefing at the start of the contest (they will not be included with the rotation sequence e-mail).

There will be staging box positions near the flight line.

If you are not ready to enter a staging box when your rotation number comes up, you will miss (forfeit) your opportunity for that rotation.

**Note: It is each team's responsibility to monitor the notifications from the scoring table in order to respond if ready. A contest official will be available to help teams enter the staging box.**

If you choose to leave the staging box for any reason, you may not attempt a flight until your turn comes up again in the rotation order.

### **Flight Course:**

The orientation (direction) of the flight course will be adjusted based on the prevailing winds as determined by the Flight Line Judge. The flight course will be positioned to maintain the greatest possible safety to personnel and facilities. The nominal flight course is shown in the Figure below.

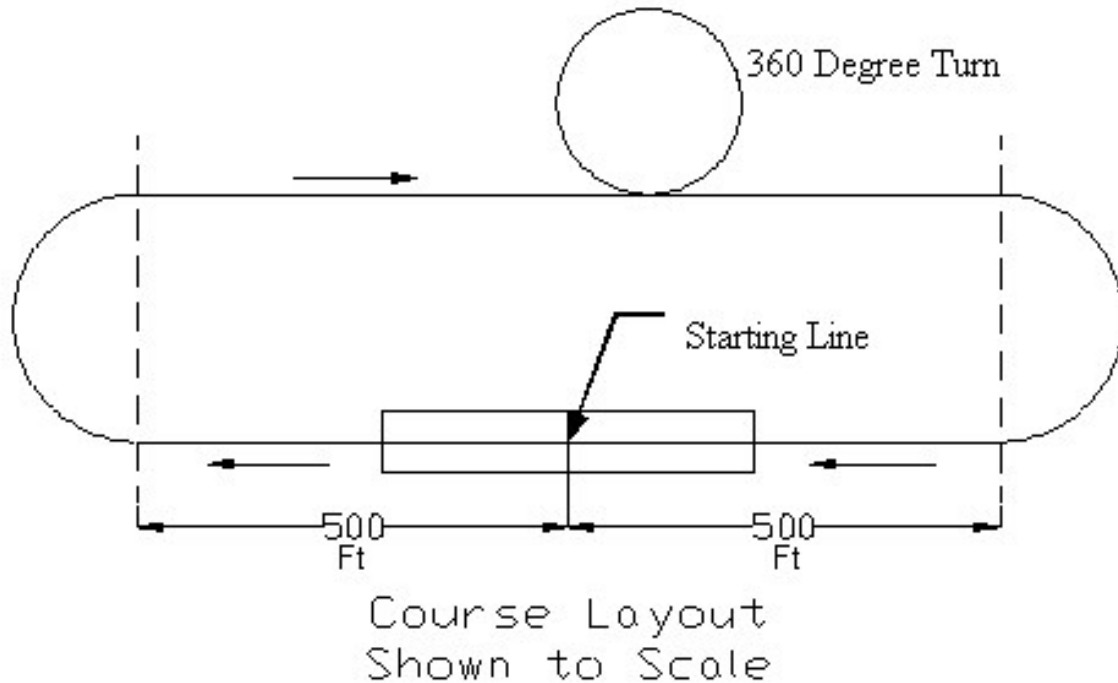

**Protest Procedure:**

Submitting a protest is a serious matter and will be treated as such. Teams may submit a protest to the Contest Administration at any time during the competition. Protests may not be submitted after the conclusion of the competition. Protests must be submitted in writing and signed by the team advisor, designees are not allowed for protest submissions. If the team advisor is not present, he may FAX or email a signed protest to the team for them to present. Remotely submitted protests must be on hard copy (printed by the team) and have the advisor’s signature. A phone number where the advisor may be contacted must be provided. Protests may be posted for review at the decision of the administration.

Protests and penalties (up to disqualification from the contest for deliberate attempts to misinform officials, violate the contest rules, or safety infractions) will be decided by the Contest Administration. Protests submitted but not upheld by the judges may be given a penalty of the loss of one flight score to the team submitting the protest. The decision of the Contest Administration is final.

## Schedule

### Entries:

The entry period OPENS 15 October at 8AM (0800) **US Eastern Time**. No entries will be accepted before that time. A completed entry must be RECEIVED by 5 PM (1700) **US Eastern Time** on 31 October. Entries will be collected through the online [Submission](#) system.

The DBF entry form is different from the ones used for other AIAA student competitions. The DBF entry form can be found in [Resources](#).

Be sure to include ALL information requested in the form. We will use the first (valid) entry received so be sure all supplied information is correct the first time.

If AIAA membership has been applied for, but a member number has not been issued, use "pending" for the member number in the entry form. The data must then be updated and resubmitted. Team rosters may be resubmitted during the Proposal and Design Report phases of the competition.

Incomplete entry forms will not be accepted.

It is the team's responsibility to make sure the e-mail contact addresses they supply remain active during the entire period from entry to the close of the competition as e-mail will be the primary means to provide information and updates. Do not use an internal team correspondence e-mail list server as your point of contact e-mail address.

**Note: The AIAA mail servers will not send e-mail to @hotmail.com addresses. Do NOT use a hotmail address for any of your team contacts or e-mail.**

### Proposal:

Teams are required to submit the proposal with the entry form via the online submission system. Entry forms and proposals are due by 5 pm (1700) **US Eastern Time** on 31 October.

The proposals will be scored as defined in the proposal requirements section. [The top 100 proposals plus ties will be invited to submit design reports and potentially become eligible for the fly-off.](#) Teams will be notified no later than 16 November if their proposal has been accepted or not.

Proposals submitted by email will not be accepted.

Proposals will be judged "as received". No corrections/additions/changes will be allowed by the organizers so check your reports carefully before submitting them. Once a Proposal is submitted, no changes are allowed.

Submission of Proposals is electronic only (no hard copy required). The details for the electronic format and submission are at the end of the report section in this rules document.

### Design Report:

Design Reports will be [submitted](#) using the [online system](#).

The design report submission period OPENS 1 February at 8AM (0800) **US Eastern Time**. The design report must be submitted by 5 pm (1700) **US Eastern Time** on 22 February.

The reports will be scored as defined in the design report requirements section. Reports submitted by email will not be accepted.

Reports will be judged “as received”. No corrections/additions/changes will be allowed by the organizers so check your reports carefully before submitting them. Once a Report is submitted, no changes are allowed.

Submission of Reports is electronic only (no hard copy required). The details for the electronic format and submission, including a requirement for an additional, separate 3-view, are at the end of the report section in this rules document.

### **Contest Fly-off:**

The contest fly-off is scheduled for 11 - 14 April 2019 and is anticipated to run from 12PM (1200) to 6PM (1800) on Thursday, 8AM (0800) to 6PM (1800) on Friday, 7AM (0700) to 6PM (1800) on Saturday and 7AM (0700) to 5PM (1700) on Sunday. Awards will be presented at 5:30PM (1730) on Sunday. All teams should plan their travel so that they may stay for the awards presentations on Sunday. A final contest schedule will be e-mailed to the teams prior to the contest date.

Tech inspections will begin on Thursday and will continue as required on Friday, Saturday and Sunday.

To help streamline the contest flow and maximize opportunities for each team to get their flights in, the Tech inspections will be conducted in the same order as the flight rotation (which is based on report scores) so that the first teams inspected will be the first teams in the flight queue. Teams may use the sequence to help estimate when they need to arrive at the contest site to make sure they do not miss their slot in the first tech inspection rotation.

### **PLEASE NOTE: All schedule deadlines are strictly enforced**

All deadlines are based on when an entry or submission is **Received** (Save and Finalize) by Contest officials via the online submission system.

Late entries and proposals will **NOT** be accepted.

Late report submissions will be disqualified.

There is no allowance for computer, internet, or power outages by the submitter, or any other type of error beyond the control of the DBF Organizing Committee.

Teams which do not submit the required electronic report and additional 3-view will **NOT** be allowed to fly.

It is the team’s responsibility to assure that all deadlines are known, understood and met.

## Mission and Vehicle Design

### Mission Task Matrix:

#### Aircraft Carrier Operations

The objective for this year is to design a multi-purpose aircraft to support carrier operations.

#### General

- The aircraft must have a minimum wing span of 4 feet
- The aircraft must have folding surfaces such that it will fit inside a space of 3 feet wide and 2 feet high in the stowed condition. The aircraft must be able to roll completely through the 3 x 2 box without interference with the box. Additionally, the nose of the aircraft and all landing gear must fit within the box within a depth of 2 feet (any part of the aircraft aft of the rear landing gear may extend outside of the box).
- The aircraft must transition from the stowed (folded) configuration to the flight configuration remotely (by command from the transmitter) and mechanically lock without any assistance.
- For all flight missions, the aircraft must take off from a launch ramp that is 4 feet wide by 10 feet long and at a launch angle of approximately 5 degrees. Low end of ramp will be the starting line for the takeoff with all landing gear on the ramp. Aircraft cannot touch the ground beyond the high side of the ramp.
- The aircraft must have a “tail hook” on the bottom, centerline of the fuselage. The tail hook must be of sufficient length, size, and strength such that the ground crew member can hold the tail hook for restraint during power up and release for take-off.
- Payloads
  - Mission 1 – no payload
  - Mission 2 –Rotating radome (see requirements)
  - Mission 3 – Attack stores (see Figure 1)



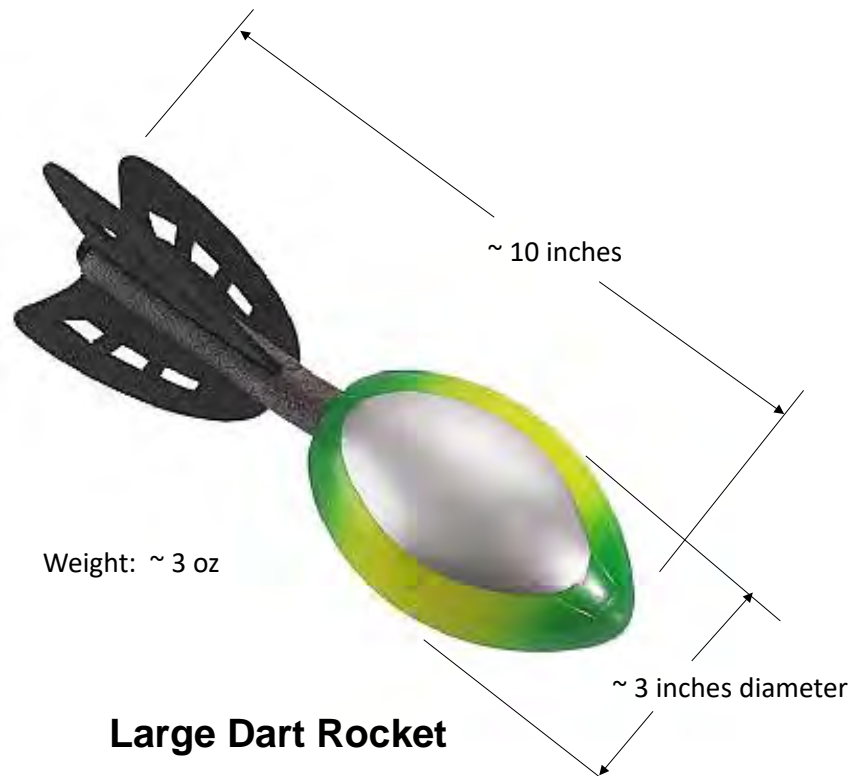

### Large Dart Rocket

Figure 1. Attack Stores.

[NOTE: Additional details on specific physical properties will be provided when available. Samples may be available from multiple promotional products sites such as [www.theexecutiveadvertising.com](http://www.theexecutiveadvertising.com)]

- Radome requirements:
  - Must be 12 inch minimum diameter and 1 inch minimum thickness in the center (attachment point)
  - The radome must be mounted on the aircraft centerline
  - There must be 3 inches minimum clearance between any part of the radome and any surface or feature of the aircraft except for the mounting structure/post
  - The radome must rotate in flight. It shall not rotate during take-off through completion of the first 180 degree turn. After the first 180 degree turn, the radome must start rotating and there must be a clear and visual indication of rotation that is easily distinguished by the flight line judges. The radome must stop rotating after the final 180 degree turn until it crosses the finish line and again, be easily distinguished by the flight line judges.
- Attack Store requirements
  - The aircraft must be capable of carrying a minimum of four (4) stores

- Must be mounted under the wings for the first four (4) stores; can be mounted under the wings or bottom of the fuselage for additional stores
- Must have a minimum of 0.5 inches clearance between stores and between the stores and any part of the aircraft except for mounting hardware
- All stores must be capable of remote detachment/separation individually and independently
- There is no limit on battery weight this year

## **General:**

### **Mission Sequence:**

- Aircraft must be designed to be capable of performing all required missions
  - During Tech Inspection, the aircraft must pass the wing tip load test in the flight condition with the largest payload loading intended to fly
  - The maximum load demonstrated will be recorded and cannot be altered after completing tech inspection
- The Flight Missions must be flown in order
  - A new mission cannot be flown until the team has obtained a successful score for the preceding mission
  - The ground mission can be attempted at any time
- After successfully completing all three flight missions, teams will be allowed one additional attempt for both Mission 2 and Mission 3 in order to improve their score.
- After successfully completing the ground mission, teams will be allowed one additional attempt to improve their score
- The aircraft will be brought to the staging box in the stowed configuration
- If you forget something you must leave the staging box and forfeit the flight attempt
- Only the assembly crew member, pilot and observer may go to and enter the staging box or Ground Mission area
- The assembly crew member is the only person who can touch the airplane while inside the staging box while preparing the aircraft for flight
- The wing deployment, radome and payload loading, and aircraft checkout must be completed in less than 5 minutes
  - A wing tip test must be conducted to verify the self-locking feature(s)
  - There is no work allowed on the aircraft after the 5-minute loading and checkout time including connection of batteries, receivers, etc. The aircraft must be ready to fly prior to being called to the flight line less the installation of the arming plug

- After radome and/or payload attachment and checkout is complete, the assembly crew member may be swapped for a different flight line crew member, if desired
- Aircraft will launch from a ramp
- The initial upwind turn on the first lap of each mission will occur after passing the turn judge (signaled by raising a flag). The aircraft must remain in unaided visual control distance of the pilot at all times. The Flight Line Judge may require turns to be made to remain in a safe visual control range at his discretion.
- Aircraft must complete a successful landing at the end of each mission for the mission to receive a score
  - A successful landing is outlined in the general mission specification section below

## Tech Inspection

- The Aircraft will enter Tech Inspection in the stowed configuration
- The aircraft will be remotely commanded to the flight condition with verification of the self-locking feature(s). Verification may include an additional wing tip test if the locking mechanism is not visible.
- Team members will install the radome and demonstrate the method of remotely enabling of rotation in flight
- Team members will load the maximum number of stores for Mission 3 and the aircraft will undergo the wing tip lift test in this configuration
- Successful remote deployment and locking of airframe
- All batteries and battery packs must be inspected during Tech Inspection. Teams should bring all possible batteries for use over the full duration of the competition to Tech Inspection

**NOTE:** New this year, teams will be allowed to have additional batteries or battery packs inspected after passing Tech Inspection due to damage, real time power change requirements, etc. However, teams must follow the Tech Inspection queue or wait until Tech Inspection is open for all for additional battery inspections. Any team that uses batteries that have not passed a Tech Inspection will lose that flight attempt and cannot attempt any further flights until the batteries have passed inspection.

## Flight Missions:

### Mission 1: Delivery Mission

- There is no payload for Mission 1
- The aircraft must enter the staging box in the stowed configuration

- The aircraft must be remotely commanded to the flight configuration, including a wing tip locking feature check, within the 5 minute staging time
- Takeoff is from the take-off ramp
- The ground crew member shall restrain the aircraft using only the tail hook at power up and release at the pilot's command
- Teams must complete 3 laps within the flight window
- There will be a 5 minute flight window for this mission
- Time starts when the aircraft is released by the flight line crew member for the first take-off (or attempt)
- A lap is complete when the aircraft passes over the start/finish line in the air (the landing is not part of the 5 minute time window)
- Time stops when the aircraft passes over the start/finish line in the air at the end of the third lap
- Must complete a successful landing to get a score

Scoring:

**M1 = 1.0** for successful mission

## **Mission 2: Reconnaissance Mission**

- The payload for Mission 2 is the rotating radome
- The aircraft must enter the staging box in the stowed configuration with the radome not installed
- The aircraft must be remotely commanded to the flight configuration, including a wing tip locking feature check, and radome installed within the 5 minute staging time
- Takeoff is from the take off ramp
- The ground crew member shall restrain the aircraft using only the tail hook at power up and release at the pilot's command
- Aircraft must complete 3 laps
- There will be a 5 minute window for this mission
- The score will be the time to complete the 3 laps
- Time starts when the aircraft is released by the flight line crew member for the first take-off (or attempt)
- A lap is complete when the aircraft passes over the start/finish line in the air (the landing is not part of the 5 minute time window)
- Time stops when the aircraft passes over the start/finish line in the air at the end of the third lap
- Must complete a successful landing to get a score

Scoring:

**M2 = 1 + [Min\_time / N\_time]** , where Min\_time is the fastest time for 3 laps of all teams

### **Mission 3: Attack Mission**

- The payload for Mission 3 are the Attack Stores
- The aircraft must enter the staging box in the stowed configuration
- Upon entering the staging box, the teams will be provided the stores requested up to the maximum validated in tech inspection
- The aircraft must be remotely commanded to the flight configuration, including a wing tip locking feature check, and stores installed within the 5 minute staging time
- Takeoff is from the take off ramp
- The ground crew member shall restrain the aircraft using only the tail hook at power up and release at the pilot's command
- After the first upwind turn, a single store will be dropped by remote command on the down wind leg of the pattern
- A scoring lap is a drop of a single store on the down wind leg of the pattern; if more than one store is dropped on a lap, the lap does not count as a scoring lap
- There will be a 10 minute window for this mission
- Time starts when the aircraft is released by the flight line crew member for the first take-off (or attempt)
- A lap is complete when the aircraft passes over the start/finish line in the air (the landing is not part of the 10 minute time window)
- Must complete a successful landing to get a score

Scoring:

**M3 = 2 + number of scoring laps**

### **Ground Mission - Flight Deck Operations and Maintenance:**

- The Ground Mission is a timed mission for a ground demonstration of Missions 2 and 3
- The mission will begin with the aircraft in the stowed configuration inside the "mission box" along with the uninstalled radome and 4 attack stores; the mission box is a 10 foot by 10 foot box
- The assembly crew members and a pilot may participate in the Ground Mission, only the assembly crew team members can touch the aircraft
- The assembly crew member and pilot will start behind the start/finish line
- Time will start when the ground mission official says "GO"

- The aircraft will be remotely commanded to the flight configuration
- The assembly crew member will install the radome and run back to the start finish line; time will stop when he/she crosses the line
- The pilot will then demonstrate the remote activation of the rotating radome
- The assembly crew member will again start behind the start/finish line and time will restart when the ground mission official says “GO”
- The assembly crew member will return to the mission box, remove the radome and install four (4) attack stores
- The assembly crew member run back to the start finish line; time will stop when he/she crosses the line
- The assembly crew member will arm the aircraft and the pilot will demonstrate all flight controls and propulsion systems are working
- The assembly crew member will disarm the aircraft
- The pilot will then demonstrate that each store can be released one at a time to complete the mission

Scoring:

**GM = [Min\_time / N\_time]** , where Min\_time is the fastest time for all teams

## **Aircraft Requirements:**

### **General**

- The aircraft may be of any configuration except rotary wing or lighter-than-air
- No structure/components may be dropped from the aircraft during flight other than the attack stores during Mission 3
- No form of externally assisted take-off is allowed. All energy for take-off must come from the on-board propulsion battery pack(s)
- Must be propeller driven and electric powered with an unmodified over-the-counter model electric motor. May use multiple motors and/or propellers. May be direct drive or with gear or belt reduction
- Motors may be any commercial brush or brushless electric motor
- For safety, each aircraft will use a commercially produced propeller/blades. Must use a commercially available propeller hub/pitch mechanism. Teams may modify the propeller diameter by clipping the tip and may paint the blades to balance the propeller. No other modifications to the propeller are allowed. Commercial ducted fan units are allowed
- You can change the propeller diameter/pitch for each flight attempt
- Motors and batteries may be limited in current draw by means of a fuse in the line from the positive battery terminal to the motor controller. There is no set limit on the fuse rating. If used, it is the

responsibility of each team to properly size the fuse to protect the battery, motor, and controller against overcurrents from any source.

- Fuse(s) must be located such that no propulsion system component: motor; motor controller; or battery may see more current than the stated limit (fuse value)
- Fuse must be placed in the positive (+) lead from the battery, and should be as close to the battery(s) as feasible
- Must use over the counter NiCad or NiMH batteries. Lithium batteries of any type are not allowed. For safety, battery packs must have shrink-wrap or other protection over all electrical contact points. The individual cells must be commercially available, and the manufacturers label must be readable/documented (i.e. clear shrink wrap preferred). **Alternatively, commercially-built pack may also be used. Any commercially-built battery packs must be properly labeled indicating cell chemistry. All battery disconnects must be "fully insulated" style connectors.**
- There is no limit to battery pack weight this year. The propulsion battery pack must power propulsion systems only. Radio Rx and servos **MUST** be on a separate battery pack. Batteries may not be changed or charged during a flight mission attempt.
- Aircraft and pilot must be AMA legal. This means that the aircraft TOGW (take-off gross weight with payload) must be less than 55-lb, and the pilot must be a member of the AMA.
- **Since this is an AMA sanctioned event, the team must submit proof that the aircraft has been flown prior to the contest date to the technical inspection team. [New this year]: Proof of flight is a video showing controlled straight and level flight. There are no exceptions to this requirement.**
- We will provide qualified pilots at the contest on an as-available basis to assist teams who are unable to have their pilot attend
- The aircraft must remain substantially the same as documented in the report (for example you cannot change a flying wing design to a conventional tail design). You may make small modifications to the design to improve flight performance after the report submission (one example would be changing a control surface size). The three-view drawing supplied in PDF form as described below in the electronic report section will be used to verify the flight article during tech inspection.
- **The aircraft must have an externally accessible switch to turn on the radio control system. It cannot be internal or under a panel or hatch.**

## **Safety:**

All vehicles will undergo a safety inspection by a designated contest safety inspector prior to being allowed to make any competition flight. All decisions of the safety inspector are final.

To speed the tech inspection, process each team must present a signed Pre-Tech and First-Flight Certification when called to begin their on-site tech inspection. Teams may not begin the on-site tech inspection without a completed certification. The Pre-Tech and First-Flight Certification sheet is available on the contest website.

The Pre-Tech must be conducted by, and signed off by, a non-team member RC pilot or the team faculty advisor. The Pre-Tech will cover the same safety of flight requirements as the on-site tech inspection and

will assist teams in making sure they are ready and able to pass the on-site tech inspection the first time. An expanded First-Flight requirement, which also must be signed off by a non team member RC pilot or the team faculty advisor, requires demonstration of a complete flight including take-off, flying a minimum flight pattern, and landing in a pre-designated location without damage to the aircraft. The non team member RC pilot who signs the inspection and flight certifications may be the same as a team's non-student contest pilot.

**Safety inspections will include the following as a minimum:**

**Physical inspection of vehicle to insure structural integrity:**

1. Verify all components adequately secured to vehicle. Verify all fasteners tight and have either safety wire, locktite (fluid) or nylock nuts. Clevises on flight controls must have an appropriate safety device to prevent their disengaging in flight
2. Verify propeller structural and attachment integrity
3. Visual inspection of all electronic wiring to assure adequate wire gauges and connectors in use
4. Radio range check, motor off and motor on
5. Verify all controls move in the proper sense
6. Check general integrity of the payload system
7. Verify folding mechanism mechanically locks

**Structural verification:**

All aircraft will be lifted with one lift point at each wing tip to verify adequate wing strength (this is "roughly" equivalent to a 2.5g load case) and to check for vehicle cg location. Teams must mark the expected empty and loaded cg locations on the exterior of the aircraft. Special provisions will be made at the time of the contest for aircraft whose cg does not fall within the wing tip chord. This test will be made with the aircraft filled to its maximum payload capacity [Radio fail-safe check](#).

All aircraft radios must have a fail-safe mode that is automatically selected during loss of transmit signal. The failsafe will be demonstrated on the ground by switching off the transmit radio. During fail safe the aircraft receiver must select:

- Throttle closed
- Full up elevator
- Full right rudder
- Full right aileron
- Full Flaps down

For aircraft not equipped with a particular control, then the safety inspector must be satisfied that the intended function of the fail-safe system will be carried out.

**The radio Fail Safe provisions will be strictly enforced:**



All aircraft must have a mechanical motor arming system separate from the onboard radio Rx switch. This may be a "blade" style fuse or an arming plug such as shown at [http://wsdeans.com/products/plugs/ultra\\_plug.html](http://wsdeans.com/products/plugs/ultra_plug.html). This device must be located so it is accessible by a crewmember standing ahead of the propeller(s) for pusher aircraft and standing behind the propeller(s) for tractor aircraft (i.e. the crew member must not reach across the propeller plane to access the arming system). The "Safety Arming Device" will be in "Safe" mode for all payload changes. The aircraft Rx should always be powered on and the throttle verified to be "closed" before activating the motor arming switch. The arming system MUST be **hard** mounted on the outside the aircraft (they cannot be behind an access panel or door) and MUST act as the "safeing" device.

Note: The aircraft must be "safed" (arming fuse/plug removed) any time the aircraft is being manually moved, or while loading/unloading payload during the mission. The arming fuse must be removed anytime the aircraft is in the hanger area.

### **General Mission Specifications and Notes:**

- The aircraft propulsion system(s) must be "safed" (fuse or arming plug removed) during any time when crew members are preparing/handling the aircraft
- Maximum flight support crew is: pilot, observer, and ground crew
- Observer and all ground crew must be students. Only the pilot may be a non-student
- The upwind turn will be made after passing the upwind marker. The downwind turn will be made after passing the downwind marker. Upwind and downwind markers will be 500 ft from the starting line. Aircraft must be "straight and level" when passing the turn marker before initiating a turn
- "Successful" Landing - Aircraft must land on the paved portion of the runway. Aircraft may "run-off" the runway during roll-out. Aircraft may not "bounce" off the runway
- Aircraft obtaining "significant" damage during landing will not receive a score for that flight. Determination of "significant" is solely at the discretion of the Flight Line Judge
- Flight altitude must be sufficient for safe terrain clearance and low enough to maintain good visual contact with the aircraft. Decisions on safe flight altitude will be at the discretion of the Flight Line Judge and all rulings will be final
- **All instructions from the Flight Line Judge must be followed IMMEDIATELY. Failure to do so may result in a loss of mission attempt or in the case of multiple or serious infractions, loss of future flight attempts**
- Additional information is included in the [FAQ](#) (Frequently Asked Questions)

## Reports

All material contained within all proposals and design reports must be original work of the teams or appropriately cited in the bibliography section of the report or in the footnotes of the proposal. All proposals and reports will be reviewed using standard AIAA tools. Any material that is found to be uncited and non-original work will be subject to a penalty as determined by the DBF Organizing Committee. Based on the severity, penalties can include points deducted from the proposal or report score up to a 100% reduction or full disqualification for the competition year.

## Proposal

Each team will submit a proposal as outlined below that will be judged.

Examples of top scoring proposals from [prior contest years](#) are posted on the contest website. Note that the formatting and content may have changed from one year to the next. Prior year proposals may not reflect or meet the rules listed for the current year.

**Note: Proposals must strictly adhere to the following requirements. Failure to meet requirements will result in penalties that range from score reduction to elimination from the contest.**

### Formatting Requirements

- Proposals must be in PDF format

**Proposals that are not in PDF format will not be accepted**

- Proposals must be one and one half line spacing with a 10-pt Arial font recommended. Text, tables and figures should be clear and readable for the judges. The proposals will be assessed for format and readability at the judges' discretion.
- Proposals must have the University name on the first page
- Absolute maximum page count for the proposal is 5 pages, the PDF reader "pages" value will be used as the official page count

**Proposals exceeding the maximum page count will not be accepted**

- Proposal PDF must be formatted as 8.5" x 11" pages

### Submission Requirements

Each team must provide an electronic copy of their proposal as outlined below to the online [Submission](#) site.

- Electronic proposal must be named: "2019DBF\_[university name]\_PROPOSAL.pdf"

**Proposals that do not meet the file naming convention above will incur a 10 point penalty**

- Electronic proposal must be a single file with all figures/drawings included in the proper sequence in PDF format.
- Electronic proposals should have all figures compressed to print resolution to minimize file size.
- Electronic proposals must be less than 20 MB in size

**Proposals exceeding the file size will incur a 10 point penalty**

### **Summary of Proposal Non-Compliance Penalties**

Requirement	Penalty
Must be in PDF format	Rejection (Not Accepted)
Maximum page count of 5 pages	Rejection (Not Accepted)
File naming convention (2019DBF_[university name]_PROPOSAL)	10 points
File size (</= 20 MB)	10 points

### **Scoring**

Proposals will be scored on a 100 point basis following the guidelines outlined below.

All information used for scoring must be in the outlined sections. **Content that is out of sequence will be treated as missing and scored accordingly.**

ALL items requested below should be present, easy to locate and identify, well documented and in the correct section for full scoring. Note that all proposals are assessed relative to each other so that simply addressing each of the sections below may not be sufficient for full credit. Proposals will be assessed on how well they communicate the required information given the size and length constraints.

### **Proposal Scoring Rubric**

All section scores include format, completeness and readability

#### Executive Summary (10 points)

- Objective Statement
- Planned approach to achieve all objectives
- Format, completeness, readability

#### Management Summary (40 points)

- Describe the organization, the roles of each team and individual skill sets required
- Organization chart (by team/function, individual names are not required for the proposal)
- Schedule / Major Milestone chart
- Budget (not only for expected materials and manufacturing of the airplane, but for travel to the competition site and any other expenses associated with the competition)
- Format, completeness, readability

#### Conceptual Design Approach (20 points)

- Describe the mission requirements (problem statement)

- Preliminary design / sizing results; concept sketch, if available (does not have to be representative of the final design)
- Sensitivity Study of Design Parameters
- Format, completeness, readability

#### Manufacturing Plan (15 points)

- Preliminary manufacturing flow
- Describe critical processes or technologies required
- Format, completeness, readability

#### Test Planning (15 points)

- Component and ground test plan
- Flight test plan
- Format, completeness, readability

## Design report

Each team will submit a design report as outlined below that will be judged.

Examples of winning team design reports from [prior contest years](#) are posted on the contest website. Note that the formatting and content has changed from one year to the next. Prior year reports may not reflect or meet the rules listed for the current year.

**Note: Reports must strictly adhere to the following requirements. Failure to meet requirements will result in penalties that range from score reduction to elimination from the contest.**

### Formatting Requirements

- Reports must be in PDF format

**Reports that are not in PDF format will not be accepted**

- Reports must be one and one half line spacing with a 10-pt Arial font recommended. Text, tables and figures should be clear and readable for the judges. The reports will be assessed for format and readability at the judges' discretion.
- Reports must have the University name on the cover page.
- Absolute maximum page count for the report is 60 pages, the PDF reader "pages" value will be used as the official page count.

**Reports exceeding the maximum page count will incur a 10 point penalty for each additional page**

- Report PDF must be formatted as 8.5" x 11" pages.
- May use 11" x 17" pages for the drawing package

- A separate stand-alone three view drawing must be submitted along with the report file. See description below in the electronic submission section.

### Submission Requirements

Each team must provide an electronic copy of their design report as outlined below to the online [Submission](#) site.

- Electronic report files must be named: “2019DBF\_[university name]\_DESIGN\_REPORT.pdf”

**Reports that do not meet the file naming convention above will incur a 10 point penalty**

- Electronic report must be a single file with all figures/drawings included in the proper report sequence in PDF format.
- Electronic reports should have all figures compressed to print resolution to minimize file size.
- Electronic reports must be less than 20 MB in size

**Reports exceeding the file size will incur a 10 point penalty**

### Stand Alone 3-view requirements:

- An additional, separate file with a one page 3-view drawing formatted to fit 8.5" x 11" paper must be submitted with the report for confirmation of the basic configuration. Note that this page does not count toward the report total
- The 3-view file shall be named as per above: “2019DBF\_[university name]\_THREE\_VIEW.pdf”
- The university and team names shall be clearly shown on the drawing
- The 3-view file is limited to 2 MB in size

### Summary of Report Non-Compliance Penalties

Requirement	Penalty
Must be in PDF format	Rejection (Not Accepted)
Maximum page count of 60 pages	10 points per additional page
Report File naming convention (2019DBF_[university name]_DESIGN_REPORT)	10 points
Report file size (<= 20 MB)	10 points

### Scoring

Reports will be scored on a 100 point basis following the guidelines outlined below.

All information used for scoring must be in the outlined sections. **Content that is out of sequence, including the drawing package, will be treated as missing and scored accordingly.**

ALL items requested below should be present, easy to locate and identify, well documented and in the correct section for full scoring. Note that all reports are assessed relative to each other so that simply addressing each of the sections below may not be sufficient for full credit. Reports will be assessed on how well they communicate the required information given the size and length constraints.

## **Design Report Scoring Rubric**

All section scores include format, completeness and readability

### Executive Summary (10 Points)

- Maximum of 2 pages. If exceeded, score as 0 points
- Summary description of selected design and why it best meets the mission
- Describe key mission requirements and associated design features
- Document the performance/capabilities of your system solution
- Format, completeness, readability

### Management Summary (5 Points)

- Describe the organization of the design team
- Chart of design personnel and assignments areas
- Milestone chart showing planned and actual timing of major elements
- Format, Completeness, Readability

### Conceptual Design (15 Points)

- Describes mission requirements (problem statement)
- Translate mission requirements into design requirements
- Review solution concepts/configurations considered
- Describe concept weighting and selection process and results
- Format, Completeness, Readability

### Preliminary Design (15 Points)

- Describe design/analysis methodology
- Document design/sizing trades
- Describe/document mission model (capabilities and uncertainties)
- Provide estimates of the aircraft lift, drag and stability characteristics
- Provide estimates of the aircraft mission performance
- Format, Completeness, Readability

### Detail Design (15 Points + 15 Points for Drawing Package)

- Document dimensional parameters of final design

- Document structural characteristics/capabilities of final design
- Document systems and sub-systems selection/integration/architecture
- Document Weight and Balance for final design
- Must include Weight & Balance table empty and with each possible payload
- Document flight performance parameters for final design
- Document mission performance for final design
- Format, Completeness, Readability
- Drawing package:
  - 3-View drawing with dimensions
  - Structural arrangement drawing
  - Systems layout/location drawing
  - Payload(s) accommodation drawing(s)

#### Manufacturing Plan (5 Points)

- Document the process selected for major component manufacture
- Manufacturing processes investigated and selection process and results
- Manufacturing milestones chart: plan and actual
- Format, Completeness, Readability

#### Testing Plan (5 points)

- Test Objectives and schedule
- Test and flight check lists
- Format, Completeness, Readability

#### Performance Results (10 Points)

- Describe the demonstrated performance of key subsystems
- Compare to predictions and explain any differences and improvements made
- Describe the demonstrated performance of your complete aircraft solution
- Compare to predictions and explain any differences and improvements made ☐ Format, Completeness, Readability

#### Bibliography (5 Points)

- List of all published works referenced in the text must be present in this section.
- Any material taken from a published source in all previous sections must have a numerical subscript corresponding to the appropriate citation in this section.

- References should appear in numerical order.
- Format should match AIAA provided guidelines:

[http://arc.aiaa.org/page/styleandformat?\\_ga=1.19023614.756532879.1456162686](http://arc.aiaa.org/page/styleandformat?_ga=1.19023614.756532879.1456162686)



## Scoring

*In the event that, due to time or facility limitations, it is not possible to allow all teams to have the maximum number of flight attempts, the contest committee reserves the right to ration and/or schedule flights. The exact determination of how to ration flights will be made on the contest day based on the number of entries, weather, and field conditions. In the event of a tie, Report Score will take precedence over Flight Score as a tie-breaker.*

## Judging

Students must design, document, fabricate, and demonstrate the aircraft they determine to be capable of achieving the highest score on the specified mission profile(s). Mission scores will be based on the demonstrated mission performance obtained during the contest.

Each team must also submit a written Design Report. A maximum of 100 points will be awarded for the team design report. The overall team score is a combination of the Design Report score and Total Mission Score. The team with the highest overall team score will be declared the winner. Scores will be FINAL 7 working days after the completion of the contest. This period will allow for review of the scores in a timely fashion following the contest.

All submitted reports are the property of AIAA, Textron Aviation and Raytheon Missile Systems and may be published or reproduced at their discretion.

## Units of Measure

The units of measure for scoring will be based on the US English system. All times or physical measurements will be rounded to the number of decimal places shown in Table 1. Conventional rounding will be implemented (<0.5 --> round down, >= 0.5 --> round up).

Units of Measure and Number of Decimal Places		
Item	Unit of Measure	Decimal Places
Time	Seconds (s)	2 (e.g. X.XX)
Length	Inches (in)	2 (e.g. X.XX)
Weight	Ounces (oz)	2 (e.g. X.XX)
	Pounds (lbs)	2 (e.g. X.XX)

## **Total Score**

Each team's overall score will be computed from their Written Report Score and Total Mission Score using the following formula:

$$\text{SCORE} = \text{Written Report Score} * \text{Total Mission Score}$$

The Total Mission Score will be computed from the individual Flight Mission and Ground Mission Scores using the following formula:

$$\text{Total Mission Score} = \text{M1} + \text{M2} + \text{M3} + \text{GM}$$

## Flyoff Site

Host for the competition will be Raytheon Missile Systems. The fly-off is planned to be held at the TIMPA facility in Tucson, AZ. Details on the contest site and schedule will be sent to registered teams early in the fly-off calendar year. You can check on historical weather conditions at [www.weatherbase.com](http://www.weatherbase.com) or [www.weatherunderground.com](http://www.weatherunderground.com).

Teams are advised to check with their airlines on what materials they will be allowed to bring both to and from the contest site. Hazmat items like paints, thinners and glues may need to be purchased locally and PROPERLY disposed of following the contest.

**\*\*NOTE: It is the team's responsibility to ensure that their aircraft arrives at the flyoff location. Neither AIAA nor the corporate sponsors will assist in getting your aircraft or materials to the flyoff location. Teams may hand carry their aircraft, use a shipping company to have it delivered to their hotel, or use any other means of transportation that they feel is appropriate. But each team must coordinate all aspects of getting the aircraft to the flyoff.**

**International Teams: Special information for non-US teams can be found [here](#).**

## FAQ

Please check the FAQ and Q&A sections often during the competition. **Please note that rules interpretation questions are not answered by e-mail until after the entry date (when all participant e-mail address are known), so that all teams will have equal access to all rules information.**

**\*\*\* All Rulings in This FAQ Supplement The Official Rules! \*\*\***

### General Notes:

2.4 GHz band radios are recommended for the contest. We will accept an email request to use a 72 MHz style radio from teams with accepted entries following the close of the entry submission period.

Lithium batteries of any type are NOT legal for use either as propulsion or RC batteries.

### Flight / Mission Questions:

**Question:** Do we have to fly all of the different missions to get a score?

**Answer:** You will get a score for each mission you successfully complete. The flights must be completed in the order specified to obtain a score.

**Question:** If the airplane is damaged on a flight can we use another copy of the aircraft which has the same design?

**Answer:** No, you must repair the original aircraft.

**Question:** Can we tailor the configuration of the aircraft differently for the different missions? For example, could we use different sized propulsion systems for each flight?

**Answer:** You cannot change the hardware configuration of the aircraft for the different missions.

**Question:** What constitutes a successful landing?

**Answer:** The aircraft must touch down ON the runway. It may roll/slide, not bounce, off the runway after touchdown.

**Question:** Is there a minimum altitude for flying the course?

**Answer:** No. Altitude must be high enough for safe flight as set by the discretion of the Contest Director.

**Question:** What would constitute “non-critical” versus “significant damage” on landing as described in the rules?

**Answer:** The decision will be at the discretion of the flight line judges. In general, “non-critical” damage would allow the aircraft to be easily returned to safe flight status. A couple of examples of “non-critical” damage would be a broken propeller, bent landing gear, sheared nylon bolts or minor scratches to the finish. If any component is structurally damaged and would be considered a hazard to safe flight then it will be considered as “significant damage”.

**Question:** At what wind speed will the contest be called.

**Answer:** It will be up to each team to determine whether they want to fly or not. The contest director will determine if it becomes unsafe for teams to fly. Wind speed is not the only factor that may be considered.

## **Aircraft Configuration Questions:**

**Questions:** Can there be thrust vectoring via rotating the engine, nozzles, blown surfaces etc.?

**Answer:** Yes. Any of the above options is allowed and may be varied during flight. However, "rotary wing" vehicles are not allowed, so you may need to consult the judges with your specific design doesn't cross over the line into vertical flight capability.

**Question:** Can we change the aircraft geometry, such as wing sweep or span, for different missions?

**Answer:** Variable geometry is allowed provided it is controlled remotely through the RC control system. You may not "swap out" parts for different missions.

**Question:** Do the external fuse accessibility requirements (from behind if tractor, from the front if pusher) exclude the use of a pusher-puller type multi-engine configuration?

**Answer:** You may use a push-pull configuration but must locate the fuse(s) such that they can be accessed by the crew member without having to reach over or around either propeller or being in the propeller disk plane of either propeller.

**Question:** Are folding propellers allowed?

**Answer:** Yes, commercial, folding propellers are allowed.

## **General Questions:**

**Question:** Is it safe to assume that if the rules do not explicitly forbid something, it is allowed?

**Answer:** The rules are intentionally designed to not impose too many limitations while allowing each team an equal chance. If something adheres to the "spirit" of the rules it is likely to be allowed. If you have any specific questions you would like clarified they may be addressed in a private e-mail to the contest administrator. Ideas will not be disclosed to other teams if they represent a legal and innovative approach. If it is deemed to be not legal, it may be added to this FAQ or posted to the other teams at the administrator's discretion.

**Question:** Do all of the team members need to be student members of AIAA?

**Answer:** Since the DBF is part of the AIAA competitions sanctioned by the Student Activities Committee and the AIAA Foundation, all team members should be student members of the AIAA.

**Question:** What is the maximum number of people that can make-up a team?

**Answer:** There is no specific limit on team size. It is up to the team itself to determine a size sufficient to meet the required tasks and small enough to remain manageable.

**Question:** Is it necessary to list all team members on the entry.

**Answer:** Yes, we need to know all the team members to verify that at least 1/3 of the team members are Freshmen, Sophomores or Juniors. Team members may be updated/changed at any time during the contest but must always comply with the 1/3 rule.

**Question:** Can we change team members during the contest year?

**Answer:** You may change team members anytime during the contest year as long as you continue to meet the team composition rules.

**Question:** Is it allowed to have/declare more than 1 pilot in a team (in case one of them cannot go to the contest, or simply have a back-up pilot)?

**Answer:** Yes, teams may register multiple pilots as long as each meets the requirements listed in the rules.

**Question:** Can we have corporate sponsors? If so, can we put their logo on the aircraft at any place that pleases them?

**Answer:** Teams may solicit and accept sponsorship in the form of funds or materials and components from commercial organizations. All design, analysis and fabrication of the contest entry is the sole responsibility of the team members. Sponsor and university decals or logos may be placed as desired.

<End FAQ>