

31 Oct 11



2011/12 Rules and Vehicle Design

Initial Rules Posting: 19 Aug 2011

Latest Update: 4 Oct 2011

Entry Deadline: 31 Oct 2011

The contest rules may be augmented/supplemented at any time during the competition.

Following the entry deadline Q&A and rules changes will be e-mailed to each team's contact e-mail address.

Summary:

The AIAA through the Applied Aerodynamics, Aircraft Design, Design Engineering and Flight Test Technical Committees and the AIAA Foundation invites all university students to participate in the **Cessna Aircraft Company/Raytheon Missile Systems - Student Design/Build/Fly Competition**. The contest will provide a real-world aircraft design experience for engineering students by giving them the opportunity to validate their analytic studies.

Student teams will design, fabricate, and demonstrate the flight capabilities of an unmanned, electric powered, radio controlled aircraft that can best meet the specified mission profile. The goal is a balanced design possessing good demonstrated flight handling qualities and practical and affordable manufacturing requirements while providing a high vehicle performance.

To encourage innovation and maintain a fresh design challenge for each new year, the design requirements and performance objectives will be updated for each new contest year. The changes will provide new design requirements and opportunities, while allowing for application of technology developed by the teams from prior years.

Check the rules package carefully as items and approaches that were legal in past years may not be legal for this contest year. Only the contents of this Rules package, the 2012 FAQ, and 2012 Q&A documents hold bearing on the requirements and/or allowances for the current contest year. It is the responsibility of the teams to know and follow all provided rules, the FAQ, and all contest day briefings.

Cash prizes are \$2500 for 1st, \$1500 for 2nd and \$1000 for 3rd place. The winning team will be invited to present their design at an AIAA conference. The team with the best Report Score will receive a \$100 prize from the Design Engineering Technical Committee.

Judging:

Students must design, document, fabricate, and demonstrate the aircraft they determine to be capable of achieving the highest score on the specified mission profile(s). Flight scores will be based on the demonstrated

mission performance obtained during the contest.

Each team must also submit a written Design Report. A maximum of 100 points will be awarded for the team design report. The overall team score is a combination of the Design Report and Flight scores. The team with the highest overall team score will be declared the winner. Scores will be FINAL 7 working days after the completion of the contest. This period will allow for review of the scores in a timely fashion following the contest.

All submitted reports are the property of AIAA, Cessna and Raytheon and may be published or reproduced at their discretion.

Contest Site:

Host for the competition will be Cessna Aircraft Company. The fly-off is planned to be held in Wichita, KS. Details on the contest site and schedule will be sent to registered teams early in the fly-off year. You can check on historical weather conditions at www.weatherbase.com or www.weatherunderground.com.

Teams are advised to check with their airlines on what materials they will be allowed to bring both to and from the contest site. Hazmat items like paints, thinners, glues may need to be purchased locally and PROPERLY disposed of following the contest.

Team Requirements:

All team members (except for a non-student pilot) must be full time students at an accredited University or College and student members of the AIAA. At least 1/3 of the team members must consist of Freshman, Sophomores or Juniors. The pilot must be an AMA (Academy of Model Aeronautics) member. Teams may use a non-university member for the pilot if desired. We will provide qualified pilots at the contest on an as-available basis to assist teams who are unable to have their pilot attend.

Each educational institution may submit one (1) team entry. The team members may be changed during the contest period, so schools may use an internal selection process to determine their final design and team members prior to the written report submission and fly-off. For schools with multiple campuses in different cities/parts of the state, each campus will be considered as a separate entity.

The number of entries is limited to a maximum of 100 teams. If more than the maximum number of team entries is received during the submission period a random selection will be used by the judges to down-select to the final team list.

Past Year Reports:

Winning team design reports from prior contest years are posted on the contest website as examples. Note that the formatting and content has evolved from one year to the next. Only the rules noted in this document apply for the current year. The top scoring report(s) from this year's contest will be placed on the contest web site for the next year's competition.

Sponsorship:

Teams may solicit and accept sponsorship in the form of funds or materials and components from commercial organizations. All **design, analysis and fabrication** of the contest entry is the sole responsibility of the student team members.

Schedule:

A completed electronic entry must be **RECEIVED** by 5 PM US East Coast Time on **31 October 2011**. Entry forms may not be submitted before **15 October**.

ε The DBF entry form is different from the ones used for other AIAA student competitions. The DBF entry

form can be found on the contest web site. It must be submitted by e-mail to the contest administrator at director@aiaadbf.org. Be sure to include **ALL** information requested in the form, incomplete forms will be returned for correction and may miss the deadline. You may only submit the form once so be sure all supplied information is included/correct the first time. **Incomplete entry forms will not be accepted.**

- *It is the teams responsibility to make sure the e-mail contact addresses they supply remain active during the entire period from entry to the close of the competition, as e-mail will be the primary means to provide information and updates. Do not use an internal team correspondence e-mail list server as your point of contact e-mail address.*

Design reports must **ARRIVE** at the Chief of Scoring address by 5 pm local time (at the report delivery address) on **28 February 2012**. Reports will be judged “as received”, no corrections/additions/page changes will be made by the organizers so check your reports carefully before sending them. **Teams must submit 5 hard copies of the report (printing details are outlined in the report section at the bottom of this document) AND one electronic copy in PDF.** *Submission of reports electronically (no hard copy required) is under review. Report submission requirements may be modified and teams notified no later than 15 January 2012.*

The contest is scheduled for **13-15 April 2012**. The competition is anticipated to run from 10AM to 7PM on Friday, 8AM to 7PM on Saturday (provided sufficient daylight remains for safe flight) and 8AM to 5PM Sunday. A final contest schedule will be e-mailed to the teams prior to the contest date. Awards will be presented at the end of Sunday's competition. All teams should plan their travel so that they may stay for the awards presentations on Sunday.

Tech inspections will begin on Friday and will be available as required on Saturday and Sunday..

To help streamline the contest flow and maximize opportunities for each team to get their flights in the Tech inspections will be conducted in the same order as the flight rotation (which is based on report scores) so that the first teams inspected will be the first teams in the flight queue. Teams may use the sequence to help estimate when they need to arrive at the contest site to make sure they do not miss their slot in the first tech inspection rotation.

Note: All schedule deadlines are strictly enforced.

Late entries will NOT be accepted. Late report submissions will NOT be judged. Teams who do not submit the required written reports will NOT be allowed to fly. It is the team's responsibility to assure that all deadlines are known, understood and met.

Communications:

Update: The AIAA mail servers will not send e-mail to @hotmail.com addresses. Do NOT use a hotmail address for any of your team contacts or e-mail. (31Oct2009)

The contest administration will maintain a World Wide Web site containing the latest information regarding the contest schedules, rules, and participating teams. The contest web site is located at:

<http://www.aiaadbf.org>

Questions regarding the contest, schedules, or rules interpretation may be sent to the contest administrator by e-mail at:

director@aiaadbf.org

Questions received prior to the official entry submission date will not be answered directly. Select questions “may” be answered in the FAQ prior to the entry submission date. Official questions and answers received following the entry submission date will be provided by e-mail to all teams of record.

Written reports should be sent to the Chief of Scoring at:

Chief of Scoring:
Tom Zickuhr
Cessna Aircraft Company
MS C5
2617 S Hoover Road
Wichita, KS 67215
316-517-1810

Aircraft Requirements - General

- ε The aircraft may be of any configuration except rotary wing or lighter-than-air.
- ε No structure/components may be dropped from the aircraft during flight.
- ε No form of externally assisted take-off is allowed. All energy for take-off must come from the on-board propulsion battery pack(s).
- ε Must be propeller driven and electric powered with an unmodified over-the-counter model electric motor. May use multiple motors and/or propellers. May be direct drive or with gear or belt reduction.
- ε Motors may be any commercial brush or brushless electric motor.
- ε For safety, each aircraft will use commercially produced propeller/blades. Must use a commercially available propeller hub/pitch mechanism. Teams may modify the propeller diameter by clipping the tip, and may paint the blades to balance the propeller. No other modifications to the propeller are allowed. Commercial ducted fan units are allowed.
- ε Motors and batteries will be limited to a maximum of **20** Amp current draw by means of a **20** Amp fuse (per motor or battery pack) in the line from the positive battery terminal to the motor controller. Only ATO or blade style plastic fuses may be used.
- ε Must use over the counter NiCad or NiMH batteries. For safety, battery packs must have shrink-wrap or other protection over all electrical contact points. The individual cells must be commercially available, and the manufacturers label must be readable/documented (i.e. clear shrink wrap preferred). All battery disconnects must be "fully insulated" style connectors.
- ε **Maximum propulsion battery pack weight is defined in the mission rules section.** This battery pack must power propulsion systems only. Radio Rx and servos MUST be on a separate battery pack. Batteries may not be changed or charged between sorties during a flight period.
- ε Aircraft and pilot must be AMA legal. This means that the aircraft TOGW (take-off gross weight with payload) must be less than 55-lb, and the pilot must be a member of the AMA.
- ε Since this is an AMA sanctioned event, the team must submit proof that the aircraft has been flown prior to the contest date (in flight photo) to the technical inspection team. Contest supplied qualified pilots will be available to teams who require them
- ε **The aircraft must remain substantially the same as documented in the report (for example you can not change a flying wing design to a conventional tail design). You may make small modifications to the design to improve flight performance after the report submission (one example would be changing a control surface size).**

Aircraft Requirements - Safety

All vehicles will undergo a safety inspection by a designated contest safety inspector prior to being allowed to

make any competition flight. All decisions of the safety inspector are final. Safety inspections will include the following as a minimum.

To speed the tech inspection process each team must present a signed ***Pre-Tech and First-Flight Certification*** when called to begin their on-site tech inspection. Teams may not begin the on-site tech inspection without a completed certification. The ***Pre-Tech and First-Flight Certification*** sheet is available on the contest website.

The Pre-Tech must be conducted by, and signed off by, a non team member RC pilot or the team faculty advisor. The Pre-Tech will cover the same safety of flight requirements as the on-site tech inspection and will assist teams in making sure they are ready and able to pass the on-site tech inspection the first time. An expanded First-Flight requirement, which also must be signed off by a non team member RC pilot or the team faculty advisor, requires demonstration of a complete flight including take-off, flying a minimum flight pattern, and landing in a pre-designated location without damage to the aircraft. The non team member RC pilot who signs the inspection and flight certifications may be the same as a team's non-student contest pilot.

- Physical inspection of vehicle to insure structural integrity.
 1. Verify all components adequately secured to vehicle. Verify all fasteners tight and have either safety wire, loctite (fluid) or nylock nuts. Clevises on flight controls must have an appropriate safety device to prevent their disengaging in flight.
 2. Verify propeller structural and attachment integrity.
 3. Visual inspection of all electronic wiring to assure adequate wire gauges and connectors in use.
 4. Radio range check, motor off and motor on.
 5. Verify all controls move in the proper sense.
 6. Check general integrity of the payload system.
- Structural verification. All aircraft will be lifted with one lift point at each wing tip to verify adequate wing strength (this is "roughly" equivalent to a 2.5g load case) and to check for vehicle cg location. Teams must mark the expected empty and loaded cg locations on the exterior of the aircraft. Special provisions will be made at the time of the contest for aircraft whose cg does not fall within the wing tip chord. This test will be made with the aircraft filled to its maximum payload capacity.
- Radio fail-safe check. All aircraft radios must have a fail-safe mode that is automatically selected during loss of transmit signal. The fail-safe will be demonstrated on the ground by switching off the transmit radio. During fail safe the aircraft receiver must select:

Throttle closed
Full up elevator
Full right rudder
Full right aileron
Full Flaps down (if so equipped)

The radio Fail Safe provisions will be strictly enforced.

- All aircraft must have a mechanical motor arming system separate from the onboard radio Rx switch. This **MUST** be the contest specified "blade" style fuse. This device must be located so it is accessible by a crewmember standing **ahead** of the propeller(s) for pusher aircraft, and standing **behind** the propeller(s) for tractor aircraft (i.e. the crew member must not reach across the propeller plane to access the fuse). The "Safety Arming Device" will be in "Safe" mode for all payload changes. The aircraft Rx should always be powered on and the throttle verified to be "closed" before activating the motor arming switch. Fuses **MUST be mounted on the outside the aircraft** (they can not be behind an access panel or door) and **MUST** act as the "safeing" device.

Note: The aircraft must be "safed" (arming fuse removed) any time the aircraft is being manually moved, or while loading/unloading payload during the mission. The arming fuse must be removed anytime the aircraft is in the hanger area.

Scoring:

In the event that, due to time or facility limitations, it is not possible to allow all teams to have the maximum number of flight attempts, the contest committee reserves the right to ration and/or schedule flights. The exact determination of how to ration flights will be made on the contest day based on the number of entries, weather, and field conditions. In the event of a tie Report Score will take precedence over Flight Score as a tie-breaker.

Each team's overall score will be computed from their **Written Report Score and Total Flight Score** using the formula:

$$\text{SCORE} = \text{Written Report Score} * \text{Total Flight Score} / \text{Sqrt(RAC)}$$

The total flight score is the sum of the individual mission flight scores: **Total Flight Score = M1 + M2 + M3**

The RAC is the maximum empty weight measured after each successful scoring flight: **RAC = Max(EW1, EW2, EW3)**

Where EWn is the post flight weight with the payload removed.

Mission Task Matrix:

Small Passenger Aircraft

General:

- ε Battery pack(s) maximum weight limit is **1-1/2** lb.
- ε Teams will be allowed a maximum of **4** flight attempts or **3** successful scoring flights. Once a mission has a successful scoring flight it may NOT be repeated to try to improve the score.
- ε All payloads must be secured sufficiently to assure safe flight without possible variation of aircraft cg during flight.
- ε All payloads must be carried fully internal to the aircraft mold lines.
- ε Assembly/flight line crew is limited to pilot, observer and 1 ground crew.

Mission Sequence:

- ε The aircraft will enter the assembly area with the payload for mission 2 and 3 uninstalled.
- ε Payload components for mission 2 and 3 will be weighed and verified.
- ε The team will have a total of 5 minutes to load the payload and checkout the aircraft systems as fully functional.
- ε There is no work allowed on the aircraft after the loading/checkout time.
 - **The RC receiver should be able to be turned on externally, you will not be allowed to re-open the payload compartment after the loading/checkout time to turn on the receiver.**
- ε Only the assembly crew member, pilot and pilot assistant may go to and enter the staging box.
 - After the checkout is complete the crew member may be swapped for a different launcher/retriever crew member if desired.
- ε **Missions will be flown in order. A new mission can not be flown until the team has obtained a successful score for the preceding mission.**
- ε **Aircraft must be designed to be capable of performing all required missions**
Specifically this requires that:
 - **Must show that all payloads fit in the aircraft during the tech inspection**
 - **Must pass the wing tip load test with the heaviest mission payload**
- ε The initial upwind turn on the first lap of each mission will occur after passing the turn judge (signaled by raising a flag). The aircraft must remain in unaided visual control distance of the pilot at all times. The **Flight Line Judge** may require turns to be made to remain in a safe visual control range at his discretion.

Missions:

- ε Aircraft will use ground rolling take-off and landing
 - Take-off distance is 100 ft. Aircraft must be off the ground and remain off the ground prior to the marked limit.
- ε The aircraft must complete a successful landing at the end of each mission for the mission to receive a score. A successful landing is outlined in the general mission specification section below.
- ε **Mission 1 - Ferry Flight**
 - Maximum number of complete laps within a **4** minute flight time
 - A lap is complete when the aircraft passes over the start/finish line in the air
 - Mission score $M1 = 1 + N_Laps/6$
 - Time starts when the throttle is advanced for the (first) take-off (or attempt)
- ε **Mission 2 - Passenger Flight**
 - 3 Lap payload flight.
 - Payload will be 8 simulated passengers
 - Simulated passengers are 1" x 1" x 5" aluminum blocks. Blocks must be rectangular, edges may be deburred, chamfered or sanded to remove sharp edges.
 - The total passenger load must weigh at least 3.75 lbs as recorded on the official contest scale
 - Simulated Passengers must be situated with long dimension vertical when aircraft is in flight.
 - There must be at least 1/2" open space fore/aft around/between each passenger and at least 1" space side-to-side between passengers or columns of passengers.
 - It is not required to have a space between the passenger nearest the outside of the aircraft and the aircraft body unless the passengers are in a single column in which case the 1" open space must be present on one side (only) of the passenger column.
 - If passengers are in a double deck arrangement there must be a structural "floor" separating the levels which must not contact the "top" of the passengers on the lower deck
 - Reasonable provisions for passenger "seats"/restraints may protrude within the specified open space area.
 - Mission score $M2 = 1.5 + 3.75/Flight_Weight (lbs)$
 - Aircraft will be weighed to obtain the Flight_Weight immediately after completion of a successful flight.
- ε **Mission 3 - Time to Climb**
 - Single take-off and climb to **100** m altitude.
 - Payload will be the team supplied "Time End Indicating System" as simulated cargo.
 - Mission score $M3 = 2 + \sqrt{T_avg/T_team}$ T_team is the time from advancing the throttle for the initial take-off (or attempt) to altitude.
 - T_avg is the average time to climb of all teams getting a successful score for Mission 3.
 - The "Time End Indicating System" will consist of:
 - A team designed and fabricated water tank with a minimum capacity of 2L.
 - The water tank will be fitted with a servo-operated "dump" valve
 - The water tank may not be pressurized but must be vented to the atmosphere. A "pitot" style vent is encouraged.
 - The system must be designed to release the stored water through an outlet located on the lower exterior surface of the aircraft
 - The resulting water plume will be utilized by the ground based contest timing officials to indicate when the aircraft has reached the required altitude
 - *It is the team's responsibility to design the system to provide a water plume sufficient (large a volume and flow rate) to be seen by the starting line judges when the aircraft is at any location on the flight course. If the water is not dumped or is not adequate to be seen to stop the time the mission will be forfeited.*
 - The "Time End Indicating System" will actuate the water release using a Soaring Circuits (<http://www.soaringcircuits.com>) CAM- f3q (aero tow model) altimeter circuit.
 - Information on the CAM-f3q system is available [here](#).
 - **Only the 100m/150m/200m model is allowed.**
 - The CAM must be installed inside the fuselage forward of the main (largest) wing. The fuselage must have a minimum of 3x 1/8" holes directly above the CAM and on the fuselage top centerline to vent the CAM to the atmosphere.
 - *The aircraft must not be designed to intentionally create a low pressure area at the CAM device.*

- Information on obtaining the CAM-f3q will be sent to registered teams following the close of the entries.
 - The water tank will be filled with 2L of water from a plastic soda bottle during the 5 min assembly period.
- There must be no loss of water between when the aircraft is loaded in the assembly area and when transiting to the staging area and to the flight line.*

Flight Line Order:

- ε A **flight order** list will be generated and **emailed to the teams on the Wednesday prior to the fly-off weekend**. Teams will always rotate in this order. The flight order will be repeated continuously.
 - The flight order list will carry over from Saturday to Sunday at what ever spot in the rotation it leaves off.
 - Each team's position in the flight order will be determined from their written report score, highest report score goes first.
 - Report **scores** will be available following the pilot briefing at the start of the contest (they will not be included with the rotation sequence e-mail).
- ε There will be four **staging box** positions near the flight line.
- ε If you are not ready to enter a **staging box** when your rotation number comes up you will miss your opportunity for that rotation.
Note: We will not call teams to the **staging box**, it is the team's responsibility to monitor the progress of the contest and decide when they need to be ready to enter an open spot in the **staging box**. A contest official will be available to help teams in entering the **staging box**.
- ε Electing to enter one of the **staging box** positions on your turn in the rotation order **will constitute using a flight attempt**.
 If you choose to leave the **staging box** for any reason you will **forfeit that flight attempt**.
 If you go to the flight line and are not able to begin your flight when instructed you will **forfeit that flight attempt**.

General Mission Specification and Notes:

- ε The aircraft propulsion system(s) must be "safed" (fuse removed) during any time when crew members are preparing/handling the aircraft.
- ε Maximum flight support crew is: **pilot, observer, and ground crew**.
- ε Observer and all ground crew must be students. **Only the pilot may be a non-student**.
- ε The upwind turn will be made after passing the upwind marker. The downwind turn will be made after passing the downwind marker. Upwind and downwind markers will be 500 ft from the starting line. Aircraft must be "straight and level" when passing the turn marker before initiating a turn.
- ε Aircraft must land on the paved portion of the runway. Aircraft may "run-off" the runway during roll-out. Aircraft may not "bounce" off the runway.
- ε *Aircraft obtaining "significant" damage during landing will not receive a score for that flight. Determination of "significant" is solely at the discretion of the Flight Line Judge.*
- ε Flight altitude must be sufficient for safe terrain clearance and low enough to maintain good visual contact with the aircraft. Decisions on safe flight altitude will be at the discretion of the Flight Line Judge and all rulings will be final.

Additional information is included in the [FAQ](#) (Frequently Asked Questions).

Flight Course:

The orientation (direction) of the flight course will be adjusted based on the prevailing winds as determined by the Flight Line Judge. The flight course will be positioned to maintain the greatest possible safety to personnel and facilities. The nominal flight course is shown in the Figure below.

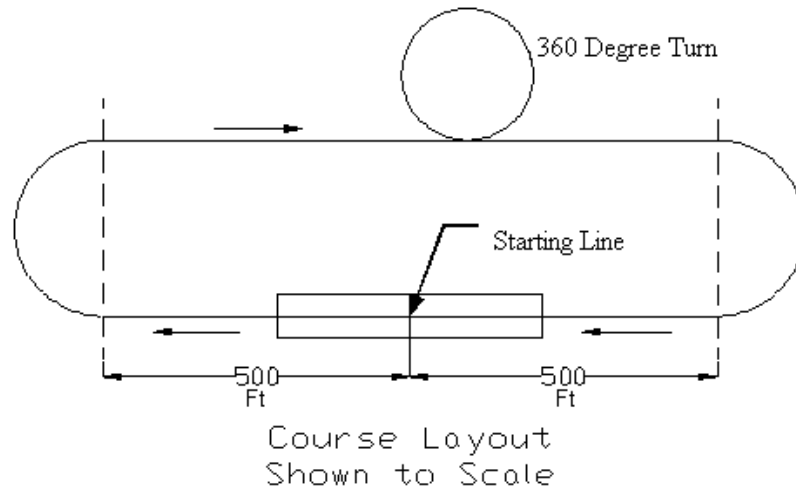

Protest Procedure:

Submitting a protest is a serious matter and will be treated as such. Teams may submit a protest to the Contest Administration at any time during the competition. Protests may not be submitted after the conclusion of the competition. Protests must be submitted in writing and signed by the team advisor, designees are not allowed for protest submissions. If the team advisor is not present, he may FAX a signed protest to the team for them to present. Protests may be posted for review at the decision of the administration.

Protests and penalties (up to disqualification from the contest for deliberate attempts to misinform officials, violate the contest rules, or safety infractions) will be decided by the Contest Administration. **Protests submitted but not upheld by the judges *may* be given a penalty of the loss of one flight score to the team submitting the protest.** The decision of the Contest Administration is final.

Design Report:

Each team will submit a judged design report as outlined below and in the **SCHEDULE** section above.

Note: Reports must strictly adhere to the following requirements. Failure to meet requirements will result penalties that range from score reduction to elimination from the contest.

- ⊖ Reports must have the University name on the cover page.
Reports missing this identification information will not be scored.
- ⊖ Reports must be bound. Simple spiral bindings are sufficient and preferred. Paper clips, 3-ring binders, or clamps are **NOT allowed**.
Stapled reports will be *penalized 10 points*
Unbound reports will not be scored.
- ⊖ Report paper may be no larger than 8 ½ inches wide by 11 inches long with the exception of the drawing package.
A4 paper may be used **ONLY** if it is cut to a maximum length of 11 inches.
The drawing package may be on 11 inch long x maximum of 17 inch wide pages.
A 10 point penalty will be given for the use of oversize paper.

- ε Absolute maximum page count for the report is **60 pages**, inclusive of all pages of any type including any form of front and back cover.
For reports printed as double sided, blank back-sides of pages **WILL** be included in the page count with the specific exceptions of:
 - 1) the back side of the very first page or cover;
 - 2) the back side of the very last page or cover;
 - 3) the back side of 11 inch x 17 inch size drawing pages.

Reports exceeding the maximum page count will be given a 10 point penalty for each additional page.

- ε Reports will be scored on a 100 point basis following the guidelines outlined below.
All information used for scoring **must be in the outlined sections, content that is out of sequence, including the drawing package, will be treated as missing** and scored accordingly.
- ε All reports must be one and one half line spacing, 10-pt Arial font. Tables and figures should be clear and readable for the judges. The reports will be judged on format and readability.
- ε **ALL** items requested below should be present, easy to locate and identify, well documented and in the correct section for full scoring.
- ε Examples of winning team design reports from prior contest years are posted on the contest website. Note that the formatting and content has changed from one year to the next. Prior year reports may not reflect or meet the rules listed for the current year.

Design Report

All section scores will include format, completeness and readability

1. Executive Summary: (10 points):
 - ... Provide a summary description of your selected design and why it is the best solution to the specified mission requirements.
 - ... Describe your key mission requirements and design features keyed to those requirements.
 - ... Document the performance/capabilities of your system solution.
2. Management Summary (5 points):
 - ... Describe the organization of the design team.
 - ... Provide a chart of design personnel and assignment areas.
 - ... Provide a milestone chart showing planned and actual timing of the design / fabrication / testing processes.
3. Conceptual Design (15 points):
 - ... Describe mission requirements (problem statement).
 - ... Translate mission requirements into design requirements.
 - ... Review solution concepts/configurations considered.
 - ... Describe concept weighting, selection process and results.
4. Preliminary Design (20 points):
 - ... Describe design/analysis methodology
 - ... Document design/sizing trades
 - ... Describe/document mission model (capabilities and uncertainties)
 - ... Provide estimates of the aircraft lift, drag and stability characteristics.
 - ... Provide estimates of the aircraft mission performance.
5. Detail Design (30 points total. 15 points for discussion items, 15 points for drawing package):
 - ... Document dimensional parameters of final design.
 - ... Document structural characteristics/capabilities of final design.
 - ... Document systems and sub-systems design/component selection/integration/architecture.
 - ... Document Weight and Balance for final design. Must include a Weight & Balance table for the empty aircraft and with each of the possible payloads
 - ... Document **flight** performance parameters for final design.

- .. Document **mission** performance for final design.
- Drawing Package
- ... 3-View drawing with dimensions.
 - ... Structural arrangement drawing.
 - ... Systems layout/location drawing.
 - ... Payload(s) accommodation drawing(s).
6. Manufacturing Plan and processes (5 points):
- ... Document the process selected for manufacture of major components and assemblies of the final design.
 - ... Detail the manufacturing processes investigated and the selection process/results.
 - ... Include a manufacturing milestone chart showing scheduled and actual event timings.
7. Testing Plan (5 points):
- ... Detail testing objectives, schedules, and check-lists.
8. Performance Results (10 points):
- ... Describe the **demonstrated** performance of key subsystems and compare it to predictions from Section 5. Explain any differences and improvements made.
 - ... Describe the **demonstrated** performance of your complete aircraft solution and compare it to predictions from Section 5. Explain any differences and improvements made.

Design Report Electronic Copy

Each team must provide an electronic copy of their final design report in addition to the hard copies used for the report judging as outlined below.

- ⌘ Electronic copy must be **RECEIVED** by the same deadline as listed above for the written reports.
- ⌘ Electronic report files must be named: “**2012DBF** *[university]* *[team name]*.PDF”
- ⌘ Electronic report must be a single file with all figures/drawings included in the proper report sequence in PDF format.
(Free PDF file conversion programs are available on the Internet, such as www.pdf995.com.)
- ⌘ Electronic reports should have all figures compressed to print resolution to minimize file size.
- ⌘ Electronic reports must be less than **20 MB** in size (including encoding for e-mail transmission) and e-mailed to: designbuildfly@gmail.com.

[\[AIAA Student Design/Build/Fly Competition homepage\]](#) [\[AIAA Homepage\]](#)



Please remember that questions submitted prior to the entry deadline of 31 October that were not answered in the FAQ must be resubmitted.

Be sure to re-check the Rules, FAQ and prior Q&A issues before submitting questions to avoid duplication.

Latest additions are in blue, but you should re-check all items in case you missed any!

DBF Q&A

7 Mar 2012

Common Topics:

- ε **Rules** – If you haven't read the rules lately you should re-read them. There were updates made between the initial **draft** rules posting and when the rules become **final** at the entry deadline. In fact, you should probably read the rules, FAQ and Q&A at least once a week for a reminder.
- ε **72 mHz Frequencies** - If any teams are still planning to use an old-style 72 mHz radio system please send an email **in January** listing your intent and requesting a channel assignment. We will try to honor channel requests on a first-come basis.
- ε **Bad email addresses:** The following team supplied mail addresses come back as invalid
micropm@nmt.edu
discusa03@yahoo
triz@ou.edu
KurtH@gmail.com
- ε **Team Updates:** We will accept team member updates to be posted on the website from 1 Feb thru 30 Feb, updates will be posted early March. Please send a "complete" copy of the entry file, although only the team member list will be processed. You may update the team composition anytime during the contest, but we will only update the website listing this one time.
- ε **Contest Site Information:** We will email contest site information and a tentative contest schedule to teams shortly.

General Questions

Q: Why does the team member name and grade information for my team shown on the teams web page look funny?

A: Information supplied is automatically processed. If you didn't follow the instructions exactly then your information will not format correctly. We will accept updates to the team member list in the spring (See the FAQ) and you may try again then.

Q: There was no mention of plane names on the entry form. Will the teams be able to submit plane names this year?

A: Since there is only one team per University team/plane names are not required to differentiate entries, we will use the University name to identify each team.

Q: Are we allowed to present our results in the SI unit system in the technical report ?

A: Teams may use English units, SI units, or both as long as they are consistent and clear to the report judges.

Q: Will spotters be allowed to aid the pilot for Mission 3?

A: Read the rules for information on the flight line crew (observer).

Q: For mission1 how will be the laps counted. Can we get a score for a partial lap?

A: Read the rules for how laps are timed/counted. Only complete laps are included in the score.

Q: What are the tolerances for dimensions required by the rules? How will they be measured or verified?

A: We will use commercial rulers or gauge blocks made using/from commercial rulers. Dimensions will not be at "micrometer" levels. We will use a commercial scale for all weights. The contest scale is the official weight.

Q: Do we have a restriction about dimensions of the box we'll use to contain plane and other stuff. Will the plane be weighed with the box or not?

A: Read the rules, there is no mention of a "box" in this years rules.

Q: Do teams need to "assemble" their aircraft when they enter the assembly area before a flight?

A: Read the rules. There is no aircraft assembly requirement in this years rules. Payload loading requirements are listed in the rules.

Q: Does the "5 minute" assembly time limit apply to payload changes during the tech inspection as well?

A: There is no specific time allotment for the tech inspection, or payload changes required during the inspection, however teams should be prepared to go through the tech inspection process efficiently. If a team is not ready to continue through the inspection sequence the inspectors have the authority to ask the team to return to complete the inspection the next time their number comes up in the inspection queue rotation which can be minutes, hours, or even a day later..

Q: Are battery pack(s) limited to 1.5 lbs/pack or 1.5lbs/plane? The rules say 1.5lbs/pack, but one could conceivable have multiple 1.5 lb packs on the plane and not violate the rules.

A: The weight limit is the weight of all **propulsion** battery pack(s) installed in the aircraft.

Q: The rules say that Battery Cells must be clearly labeled. Does this mean that each individual battery cell must be labeled?

A: If the cells are not labeled or are not visible we will accept an invoice clearly stating the cells used in the pack (s).

Q: Is it legal to mount the batteries on the exterior top surface of the fuselage?

A: No, batteries must be contained inside the aircraft surfaces.

Q: For the structural wing tip test, will the load be applied at the ends of winglets or other wingtip devices, or at the tip of the main span of the wing?

A: The lift point will be as far out the span of the wing as is possible. See the FAQ for additional information.

Q: Can we create a micro-controller that will dynamically limit the throttle of our plane in order to remain under the 20 Amp limit?

A: No. You may not put anything between the Rx and the motor and/or any servo that will modify the PWM signal and may interfere with with the fail-safe. You may use telemetry to notify the pilot of current draw.

Q: Would it be legal to intentionally cool the fuse before flying each mission?

A: No. That would violate the "intent" of the rules.

Q: Is it legal to use tape to secure our top hatch?

A: You may use tape for typical model aircraft functions such as holding hatches in place.

Q: Can we machine our own gearboxes or must they be commercially available?

A: You may make your own using commercial gears or may modify a commercial gearbox.

Mission Questions

Q: Can we use some type of dye or coloring to make the water more visible during mission 3?

A: No. You may only use plain tap water. Making the water plume visible should be part of your release system design.

Q: Does airplane need to have a fuselage during M1, could we put off the required fuselage for mission 2 and mission 3 during mission 1? For mission 2 and 3, are we allowed to add attachments to the fuselage which will carry the payloads?

A: No. Read the rules General section and FAQ Flight/Mission #2 and Aircraft #3..

Q: Does "flight weight" in mission 2 include the payload? What about the empty weight?

A: Flight weight in mission 2 includes the passenger payload. RAC for mission 2 does not include the passengers but does include all passenger accommodations. RAC for mission 3 does not include the water but does include the water storage and release system.

Q: The rules state "The aircraft will enter the assembly area with the payload for mission 2 and 3 uninstalled." Does this mean that the team must begin Mission 3 assembly with the entire TEIS (the specified payload for Mission 3) removed, or can components of the TEIS be installed in the aircraft before entering the assembly area?

A: The TEIS should be installed prior to entering the assembly area. The water is the payload for mission #3, which will be filled in the assembly area.

Q: Do the passenger restraints need to be installed in the aircraft for mission #1 and #3?

A: Teams may decide if they want the passenger restraints (or portions) installed in the aircraft during Missions 1 or 3.

Q: May passenger restraints also serve as aircraft structural components?

A: No.

Q: In mission 3 must all of the water be dropped before the aircraft lands?

A: There is no requirement in the rules specifying how much water must be released.

Q: If all water is not released during the flight, will the RAC will be calculated with or without the residual water in the tank?

A: You may release any residual water that will self-exit the tank before the post-flight weight measurement

Q: The above question says that the residual water may self-exit the tank. Is it allowed to turn the aircraft such way that our trapped water will eventually will exit the tank?

A: You may command the exit valve open and tip the airplane but you may not tilt the aircraft beyond vertical in any plane (ie. can't turn it upside down).

Q: Are the teams responsible for providing the 2L of water or the 2L container that said payload is loaded into the aircraft from? If so, how will the volume be confirmed by the judges?

A: The organizers will have several 2L water bottles that will be used to fill the aircraft during tech inspection and during the pre-flight assembly period.

Q: May water be intentionally dropped upon or immediately after takeoff to reduce aircraft weight?

A: No. The CAM device must be the only means by which water can be released and water must not be released until the CAM device senses the specified release altitude.

Q: In reference to the following passage from the rules regarding mission 3, "Single take-off and climb to 100 m altitude" There is no mention of completing laps for mission three. Are there flight pattern restrictions for mission 3?

A: The aircraft must complete a normal flight lap, the same as prescribed for other missions, and make a successful landing the same as any other mission.

Q: Does a propeller have to be installed on all motors during flight?

A: No.

Q: Can we change propellers/gear ratios between flights?

A: See the FAQ, you may change propellers. If the aircraft and gearbox configuration is the same you may change gear ratios.

Q: Will binoculars (or any other visual aid) be used by the judge who runs the stop watch for Mission 3?

A: The judges do not intend to use any magnification device to see the water drop. As stated in the rules, it is the teams responsibility as part of their design to make sure the water drop can be seen from any point the aircraft is on along the course.

Aircraft Questions

General

Q: If our team wants to use a 3D printer to print a part designed and modeled by the team, but the printer belongs to another organization, how much involvement from students would be required in the print process?

A: See FAQ Aircraft Questions #4.

Q: Is adding/removing tape on the aircraft between missions allowed?

A: It depends what the tape is being used for.

Q: Is it possible to use two sets of wing that have different airfoil for different mission?

A: No, read the FAQ for details on allowable variable geometry.

Q: Are we allowed to use different battery packs for the different missions? To clarify, we do not mean a number of identical packs, rather that each pack contains a different number of batteries and different kind of battery cells as well.

A: Re-read the rules. You may have different size/configuration/weight battery packs as long as all meet the rules (including battery type/chemistry) and all are presented, inspected and approved during the tech inspection.

Mission 2 Payload

Q: Can the passenger block be modified for weight reduction by drilling holes through the blocks?

A: No, you may not drill holes in the passengers. Read the rules for what modification to the blocks is allowed.

Q: Is there a specification for the amount of chamfer/deburring allowed for the passenger block?

A: Read the rules for what modification to the blocks is allowed. Any deburring, chamfering, or sanding beyond what is required for safe handling (ie. to remove sharp edges) is illegal and will result in a failed tech inspection.

Q: Can we attach velcro, screws or other items to the "passengers" to help hold them in the aircraft?

A: You may not make any modification to the passengers, including attachments, other than what is described in the rules.

Q: Can we use sticky tape or "tack it" on the floor and on the side wall and place the passengers on them?

A: As noted above, you can't glue/tape items to the passengers, that includes attaching the airplane to the passengers (or the passengers to the airplane).

Q: Should the spar box obey the 0.5" gap rule between an aluminum block or is 0.5" aft-fore rule just a matter for block placement?

A: The rules say "open space". Note the comment in the rules on "seats"/mounting.

Q: the rules writes There must be at least 1/2" open space fore/aft around/between each passenger. Are we

allowed to select fore-aft or around-between or do we have to use both of them

A: You must meet all of the clearance requirements (all sides) as specified.

Q: For Mission 2, if the passengers were to be aligned in a single row which requires a 1" space to one side of the passengers totaling a in a 2" wide payload, this would cause a balancing issue. Is it allowed to stagger the passengers so that each passenger has 1" to the side of them but they are not technically in a row.

A: If the passengers "switch sides" in the aircraft then the 1" wide *aisle* must continue across between the passengers at the stagger. Note also that the exclusion for spacing between a passenger and the side of the aircraft does NOT apply to the side(s) of a removable payload insert.

Q: For Mission 2, must the blocks be rigidly fixed within the aircraft or is some amount of movement/shifting allowed?

A: The payload must be sufficiently secured to prevent shifting during flight. Payload integrity will be checked during the tech inspection.

Q: Must passengers stay restrained during landing?

A: They may not exit or damage the aircraft during landing.

Q: In the rules it is stated that "reasonable provisions for passenger "seats"/restraints may protrude within the specified open space area." I know that the restraints may not cover the blocks completely, but what is considered acceptable?

A: You may have no more than 2 x 1/4" tall contact points (per passenger side) between the passenger and the restraints to hold them in their location. The passenger may however "sit" on the floor, seat or other platform on the bottom.

Mission 3 Payload

Q: Is locating the altimeter circuit in the fuselage aft of a tractor propeller considered intentionally placing the circuit in a region of low pressure?

A: Read the rules for information on pressure port requirements. Being behind a propeller will not necessarily place the port in a "intentional" low pressure area.

Q: Does a downward-facing angled surface count as a bottom exterior surface? (i.e angled aft fuselage or angled wing tips)

A: This is too general to answer concisely, if you have a specific configuration question you may submit a Confidential question including the details (drawings) of your aircraft design and location.

Q: The mission description says, the release valve has to be servo operated. Is it correct to assume that as long as the release mechanism is actuated by a servo, the team can design any type of release mechanism such as a trap door or a plug type opening for the water release?

A: You can use any type of "valve" as long as it meets the actuation required in the rules. Be sure to also read the requirements on water "loss" in the mission 3 section.

Q: As a water valve, may we use a form of a solenoid? Instead of having the CAM system control a servo, we would have it link to an electromagnet, opening and closing the valve.

A: The rules say the valve must be operated by a normal model servo.

Q: Can we attach a switch between the CAM and our time-end indicating system's servo? Our concern is that a long time will pass between the pre-tech and the actual flight (due to weather conditions or any other reasons) which will empty our battery.

A: You will need to develop an appropriate control system and process for the CAM to retain it's settings between when the system is armed in the assembly area and when your flight begins.

Q: Is there any restriction for the material and ingredient of water tank?

A: No, normal aircraft construction and materials are acceptable. Note that collapsible/elastic tanks are considered "pressurized" and are not allowed.

Q: Are bladders included under the definition of "collapsible" water tanks?

A: Yes if they are flexible/elastic/collapsible or made from flexible/elastic/collapsible materials. Any surface or component in contact with the water is considered part of the water tank.

Q: Could you please elaborate further on what constitutes a "flexible" material or define a thickness that would be considered "rigid"?

A: Material should be selected such that it is *obvious to the tech inspectors* if it qualifies, they have the final decision. If you are looking at a material (not your assembly) and when you take a piece and bend it and it springs back it is probably rigid. If you hold a piece of the material vertical from the bottom and it folds over on it's own it is not rigid.

Q: Can plumbing for the water system other than the tank use flexible materials?

A: See above, the "tank" may not be flexible/elastic/collapsible. Elements other than the tank including inlet/outlet plumbing may use flexible materials

Q: A "pitot" style vent has the potential to pressurize the water tank from the ram-air effect. Is this style of ventilation system still allowed?

A: The pitot vent is specifically allowed. Vents should be constant diameter, not a "funnel" designed specifically to increase pressure.

Q: During the Tech Inspection, will the water be put in the aircraft for the wingtip test or can an equivalent weight be used?

A: During tech inspection teams will demonstrate that the aircraft can hold the required volume of water. Since the water payload is the heaviest payload it will be used during the wing tip load test.

Q: Since the "Time End Indicating System" (TEIS) is considered a payload for mission three, does that mean that all required attributes of the TEIS, including the water tank, must be removable from (not built into) the aircraft structure?

A: Teams may decide if they want the TEIS (or portions) installed in the aircraft during Missions 1 or 2.

Q: Is the water tank allowed to be simply the outer surface of the fuselage, or must it be a separate structure?

A: As stated above, different elements of the TEIS may be either fixed or removable.

Q: Can teams use a funnel when pouring the 2L of water from the plastic bottle into the water tank? Would the funnel be considered part of the empty aircraft weight?

A: Teams may use "ground support" devices during the water loading. Anything that remains with the aircraft during flight will be part of the aircraft empty weight.

Q: In the case of an aircraft configuration such as the Blended-Wing-Body, which does not have clear distinction between fuselage and wing, where must the CAM be placed?

A: As stated in the rules *The aircraft must not be designed to intentionally create a low pressure area at the CAM device*, which also means the CAM must not be placed in a location such that it sees a configuration created low pressure.