

3 Nov 10



## 2010/11 Rules and Vehicle Design

Rules Posting: 21 Aug 2010

Entry Deadline: 31 Oct 2010

*The contest rules may be augmented/supplemented at any time during the competition. Following the entry deadline Q&A and rules changes will be e-mailed to each teams contact e-mail address.*

*Rules are not FINAL until 31 Oct Entry Deadline*

### Summary:

The AIAA through the Applied Aerodynamics, Aircraft Design, Design Engineering and Flight Test Technical Committees and the AIAA Foundation invites all university students to participate in the **Cessna Aircraft Company/Raytheon Missile Systems - Student Design/Build/Fly Competition**. The contest will provide a real-world aircraft design experience for engineering students by giving them the opportunity to validate their analytic studies.

Student teams will design, fabricate, and demonstrate the flight capabilities of an unmanned, electric powered, radio controlled aircraft that can best meet the specified mission profile. The goal is a balanced design possessing good demonstrated flight handling qualities and practical and affordable manufacturing requirements while providing a high vehicle performance.

To encourage innovation and maintain a fresh design challenge for each new year, the design requirements and performance objectives will be updated for each new contest year. The changes will provide new design requirements and opportunities, while allowing for application of technology developed by the teams from prior years.

*Check the rules package carefully as items and approaches that were legal in past years may not be legal for this contest year. Only the contents of this Rules package, the 2010/11 FAQ, and 2010/11 Q&A documents hold bearing on the requirements and/or allowances for the current contest year.* It is the responsibility of the teams to know and follow all provided rules, the FAQ, and all contest day briefings.

Cash prizes are \$2500 for 1<sup>st</sup>, \$1500 for 2<sup>nd</sup> and \$1000 for 3<sup>rd</sup> place. The winning team will be invited to present their design at the AIAA/U.S. Air Force T&E Days conference. The team with the best Report Score will receive a \$100 prize from the Design Engineering Technical Committee.

### Judging:

Students must design, document, fabricate, and demonstrate the aircraft they determine to be capable of

achieving the highest score on the specified mission profile(s). Flight scores will be based on the demonstrated mission performance obtained during the contest.

Each team must also submit a written Design Report. A maximum of 100 points will be awarded for the team design report.

The overall team score is a combination of the Design Report and Flight scores. The team with the highest overall team score will be declared the winner.

Scores will be FINAL 7 working days after the completion of the contest. This period will allow for review of the scores in a timely fashion following the contest.

All submitted reports are the property of AIAA, Cessna and Raytheon and may be published or reproduced at their discretion.

### Contest Site:

Host for the competition will be Raytheon Missile Systems. The fly-off is planned to be held in Tucson, AZ. You can check on historical weather conditions at [www.weatherbase.com](http://www.weatherbase.com) or [www.weatherunderground.com](http://www.weatherunderground.com).

### Team Requirements:

All team members (except for a non-student pilot) must be full time students at an accredited University or College and student members of the AIAA. At least 1/3 of the team members must consist of Freshman, Sophomores or Juniors. The pilot must be an AMA (Academy of Model Aeronautics) member. Teams may use a non-university member for the pilot if desired. We will provide qualified pilots at the contest on an as-available basis to assist teams who are unable to have their pilot attend.

**There may be a maximum of two (2) teams entered from any one educational institution. For schools with multiple campuses in different cities/parts of the state, each campus will be considered as a separate entity. Schools are encouraged to combine small teams (less than 10 members) rather than enter two separate teams. If two teams are entered you may choose to drop one team and combine the members into a single team prior to the report submission.**

### Past Year Reports:

Winning team design reports from prior contest years are posted on the contest website as examples. Note that the formatting and content has evolved from one year to the next. Only the rules noted in this document apply for the current year. The top scoring report(s) from this year's contest will be placed on the contest web site for the next year's competition.

### Sponsorship:

Teams may solicit and accept sponsorship in the form of funds or materials and components from commercial organizations. All **design, analysis and fabrication** of the contest entry is the sole responsibility of the student team members.

### Schedule:

A completed electronic entry must be **RECEIVED** by 5 PM US East Coast Time on **31 October 2010**. Entry forms may not be submitted before **1 October**.

- ε The DBF entry form is different from the ones used for other AIAA student competitions. The DBF entry form can be found on the contest web site. It must be submitted by e-mail to the contest administrator at [director@aiaadbf.org](mailto:director@aiaadbf.org). Be sure to include **ALL** information requested in the form, incomplete forms will be returned for correction and may miss the deadline. **Incomplete entry forms will not be accepted.**

- ε *It is the teams responsibility to make sure the e-mail contact addresses they supply remain active during the entire period from entry to the close of the competition, as e-mail will be the primary means to provide information and updates. Do not use an internal team correspondence e-mail list server as your point of contact e-mail address.*
- ε The **Entry Name** may not be changed once the form is submitted, but must be retained and used on all reports and e-mail/correspondence during the competition year.

Design reports must **ARRIVE** at the Chief of Scoring address by 5 pm local time (at the report delivery address) on **1 March 2011**. Reports will be judged “as received”, no corrections/additions/page changes will be made by the organizers so check your reports carefully before sending them. **Teams must submit 5 hard copies of the report** (printing details are outlined in the report section at the bottom of this document) **AND** one electronic copy in PDF. **Only the hard copies will be used for judging.**

The contest is scheduled for **15-17 April 2011**. The competition is anticipated to run from 10AM to 7PM on Friday, 8AM to 7PM on Saturday (provided sufficient daylight remains for safe flight) and 8AM to 5PM Sunday. A final contest schedule will be e-mailed to the teams prior to the contest date. Awards will be presented at the end of Sunday's competition. All teams should plan their travel so that they may stay for the awards presentations on Sunday.

Tech inspections will begin on Friday **15 April**.

**NEW THIS YEAR:** To help streamline the contest flow and maximize opportunities for each team to get their flights in the Tech inspections will be conducted in the same order as the flight rotation (which is based on report scores) so that the first teams inspected will be the first teams in the flight queue. Teams may use the sequence to help estimate when they need to arrive at the contest site to make sure they do not miss their slot in the first tech inspection rotation.

**Note: All schedule deadlines are strictly enforced.**

**Late entries will NOT be accepted. Late report submissions will NOT be judged. Teams who do not submit the required written reports will NOT be allowed to fly. It is the team's responsibility to assure that all deadlines are known, understood and met.**

## Communications:

**Update: The AIAA mail servers will not send e-mail to @hotmail.com addresses. Do NOT use a hotmail address for any of your team contacts or e-mail. (31Oct2009)**

The contest administration will maintain a World Wide Web site containing the latest information regarding the contest schedules, rules, and participating teams. The contest web site is located at:

<http://www.aiaadb.org>

Questions regarding the contest, schedules, or rules interpretation may be sent to the contest administrator by e-mail at:

[director@aiaadb.org](mailto:director@aiaadb.org)

Questions received prior to the official entry submission date will not be answered directly. Select questions “may” be answered in the FAQ prior to the entry submission date. Official questions and answers received following the entry submission date will be provided by e-mail to all teams of record.

Written reports should be sent to the Chief of Scoring at:

**AIAA Design/Build/Fly Contest/Report Judging**

Matt Angiulo  
2196 S. Thunder Tanner Dr.  
Tucson, AZ 85748  
520-663-6004

## Aircraft Requirements - General

- ε The aircraft may be of any configuration except rotary wing or lighter-than-air.
- ε No structure/components may be dropped from the aircraft during flight.
- ε No form of externally assisted take-off is allowed. All energy for take-off must come from the on-board propulsion battery pack(s). **Energy imparted by the hand launch is allowed and not excluded by this requirement.**
- ε Must be propeller driven and electric powered with an unmodified over-the-counter model electric motor. May use multiple motors and/or propellers. May be direct drive or with gear or belt reduction.
- ε Motors may be any commercial brush or brushless electric motor.
- ε For safety, each aircraft will use commercially produced propeller/blades. Must use a commercially available propeller hub/pitch mechanism. Teams may modify the propeller diameter by clipping the tip, and may paint the blades to balance the propeller. No other modifications to the propeller are allowed. Commercial ducted fan units are allowed.
- ε Motors and batteries will be limited to a maximum of **20** Amp current draw by means of a **20** Amp fuse (per motor or battery pack) in the line from the positive battery terminal to the motor controller. Only ATO or blade style plastic fuses may be used.
- ε Must use over the counter NiCad or NiMH batteries. For safety, battery packs must have shrink-wrap or other protection over all electrical contact points. The individual cells must be commercially available, and the manufacturers label must be readable/documented (i.e. clear shrink wrap preferred). All battery disconnects must be "fully insulated" style connectors.
- ε **Maximum propulsion battery pack weight is defined in the mission rules section.** This battery pack must power propulsion systems only. Radio Rx and servos MUST be on a separate battery pack. Batteries may not be changed or charged between sorties during a flight period.
- ε Aircraft and pilot must be AMA legal. This means that the aircraft TOGW (take-off gross weight with payload) must be less than 55-lb, and the pilot must be a member of the AMA.
- ε Since this is an AMA sanctioned event, the team must submit proof that the aircraft has been flown prior to the contest date (in flight photo) to the technical inspection team. Contest supplied qualified pilots will be available to teams who require them.

## Aircraft Requirements - Safety

All vehicles will undergo a safety inspection by a designated contest safety inspector prior to being allowed to make any competition flight. All decisions of the safety inspector are final. Safety inspections will include the following as a minimum.

**NEW THIS YEAR:** To speed the tech inspection process each team must present a signed **Pre-Tech and First-Flight Certification** when called to begin their on-site tech inspection. Teams may not begin the on-site tech inspection without a completed certification. The **Pre-Tech and First-Flight Certification** sheet is available on the contest website.

The Pre-Tech must be conducted by, and signed off by, a non team member RC pilot or the team faculty

advisor. The Pre-Tech will cover the same safety of flight requirements as the on-site tech inspection and will assist teams in making sure they are ready and able to pass the on-site tech inspection the first time. An expanded First-Flight requirement, which also must be signed off by a non team member RC pilot or the team faculty advisor, requires demonstration of a complete flight including take-off, flying a minimum flight pattern, and landing in a pre-designated location without damage to the aircraft. The non team member RC pilot who signs the inspection and flight certifications may be the same as a teams non-student contest pilot.

- Physical inspection of vehicle to insure structural integrity.
  1. Verify all components adequately secured to vehicle. Verify all fasteners tight and have either safety wire, locktite (fluid) or nylock nuts. Clevises on flight controls must have an appropriate safety device to prevent their disengaging in flight.
  2. Verify propeller structural and attachment integrity.
  3. Visual inspection of all electronic wiring to assure adequate wire gauges and connectors in use.
  4. Radio range check, motor off and motor on.
  5. Verify all controls move in the proper sense.
  6. Check general integrity of the payload system.
- Structural verification. All aircraft will be lifted with one lift point at each wing tip to verify adequate wing strength (this is "roughly" equivalent to a 2.5g load case) and to check for vehicle cg location. Teams must mark the expected empty and loaded cg locations on the exterior of the aircraft. Special provisions will be made at the time of the contest for aircraft whose cg does not fall within the wing tip chord. This test will be made with the aircraft filled to its maximum payload capacity.
- Radio fail-safe check. All aircraft radios must have a fail-safe mode that is automatically selected during loss of transmit signal. The fail-safe will be demonstrated on the ground by switching off the transmit radio. During fail safe the aircraft receiver must select:

Throttle closed  
 Full up elevator  
 Full right rudder  
 Full right aileron  
 Full Flaps down (if so equipped)

**The radio Fail Safe provisions will be strictly enforced.**

- All aircraft must have a mechanical motor arming system separate from the onboard radio Rx switch. This **MUST** be the contest specified "blade" style fuse. This device must be located so it is accessible by a crewmember standing **ahead** of the propeller(s) for pusher aircraft, and standing **behind** the propeller(s) for tractor aircraft (i.e. the crew member must not reach across the propeller plane to access the fuse). The "Safety Arming Device" will be in "Safe" mode for all payload changes. The aircraft Rx should always be powered on and the throttle verified to be "closed" before activating the motor arming switch. Fuses **MUST be mounted on the outside the aircraft** (they can not be behind an access panel or door) and **MUST** act as the "safeing" device.

Note: The aircraft must be "safed" (arming fuse removed) any time the aircraft is being manually moved (**except during the hand launch**), or while loading/unloading payload during the mission. The arming fuse must be removed anytime the aircraft is in the hanger area.

## Scoring:

*In the event that, due to time or facility limitations, it is not possible to allow all teams to have the maximum number of flight attempts, the contest committee reserves the right to ration and/or schedule flights. The exact determination of how to ration flights will be made on the contest day based on the number of entries, weather, and field conditions. In the event of a tie Report Score will take precedence over Flight Score as a tie-breaker.*

Each team's overall score will be computed from their **Written Report Score and Total Flight Score** using the formula:

**Updated:** **SCORE = Written Report Score \* Total Flight Score / Sqrt(RAC)**

The total flight score is the sum of the individual mission flight scores: **Total Flight Score = M1 + M2 + M3**

The RAC is the maximum empty weight measured after each successful scoring flight: **RAC = Max(EW1, EW2, EW3)**

Where EWn is the post flight weight with the payload removed.

## Mission Task Matrix:

### Soldier Portable UAV

#### General:

- ε Battery pack(s) maximum weight limit is **3/4** lb.
- ε Teams will be allowed a maximum of **4** flight attempts or **3** successful scoring flights. Once a mission has a successful scoring flight it may NOT be repeated to try to improve the score.
- ε The complete UAV flight system must fit in a commercially produced **suitcase** meeting airline carry-on bag rules as shown in the figure below.
  - Carry-on must not exceed 45 linear inches as shown in diagram. No single dimension can exceed 22"
  - Measured dimensions will not include movable items (handles, zipper tags) but will include fixed items (wheels, stands).
  - Carry on suitcase must latch or zip closed to fully enclose contents. It may not be a sack, bag, box, backpack, briefcase, laptop case, shoulder bag/purse/tote or equipment case.
  - You may add interior supports but may not remove any factory items except the interior cloth lining to make attaching the interior supports easier
  - The case must include the complete "flight" system consisting of the aircraft, propulsion battery, and all required parts and tools to assemble a flight ready aircraft.
  - The pilots control transmitter is NOT part of the flight system and does not need to be in the suitcase.
- ε All payloads must be secured sufficiently to assure safe flight without possible variation of aircraft cg during flight.
- ε All payloads must be carried fully internal to the aircraft mold lines.
- ε Assembly/flight line crew is limited to pilot, observer and 1 ground crew who will be the assembler/launcher/retriever. The aircraft assembly must be performed by the single ground crew member as would be typical of a single soldier portable system.
- ε **Golf ball payload for this years contest will be provided by the contest administration.**
- ε Golf balls will be [legal USGA balls](#). Teams can research the allowable weight and size at the highlighted link.
- ε **Steel Bar payload will be provided by each team.**





### Mission Sequence:

- ε The UAV system (including pre-installed payload when flying Mission 2) will be brought to the staging box inside the carry-on bag.
  - ↳ If you forget something you must leave the staging box and forfeit the flight attempt.
- ε Upon entering the staging box the single ground crew member will assemble and flight check the aircraft (prior to being called to the flight line).
  - ↳ The assembly and checkout must be completed in less than 5 minutes.
  - ↳ There is no work allowed on the aircraft after the 5 minute assembly and checkout time.
  - ↳ Only the assembly crew member, pilot and pilot assistant may go to and enter the staging box.
  - ↳ After the assembly is complete the assembly crew member may be swapped for a different launcher/retriever crew member if desired.
- ε **Missions will be flown in order. A new mission can not be flown until the team has obtained a successful score for the preceding mission.**

### Missions:

- ε Aircraft will be hand launched in a direction away from the crowd as designated by the flight line judge.
  - ↳ Hand launches must be accomplished by holding the fuselage, no wingtip/discus launches allowed.
  - ↳ Teams may not use a "hand launch assist" device (such as a spear-thrower or any type of arm extender).
  - ↳ The aircraft must be released before crossing the start/finish line in the direction of the flight pattern.
  - ↳ For a launch to be ruled "successful" the aircraft must stay airborne after leaving the launchers hand. Any contact with the ground or a ground based object constitutes a failed launch.
  - ↳ There is no runway length requirement this year.
- ε Teams may make a maximum of **3** launch attempts during a single flight attempt. **No repairs may be made between launch attempts.**
- ε The aircraft must complete a successful landing at the end of a mission for the mission to receive a score. A successful landing is outlined in the general mission specification section below.
- ε **Mission 1 - Dash to critical target**
  - ↳ Maximum number of COMPLETE laps in a **4** minute flight time
  - ↳ Mission score  $M1 = N\_laps / N\_max$ .  $N\_max$  will be the maximum number of complete laps obtained by any team getting a successful score for this mission.
  - ↳ Flight time is from leaving the launchers hand during the (first) hand launch (or attempt) to completion of the last scored lap when the aircraft passes over the start/finish line while still in the air
- ε **Mission 2 - Ammo Re-Supply**
  - ↳ 3 Lap payload flight.
  - ↳ Payload will be the team selected (and supplied) steel bar payload. Steel bars must be a

minimum 3" width x 4" length.

- Mission score  $M2 = 3 \times \text{Payload\_Weight} / \text{Flight\_Weight}$
- Aircraft will be weighed to obtain the Flight\_Weight immediately after completion of a successful flight.
- Payload will be removed (by the team) and weighed to obtain the Payload\_Weight immediately after completion of a successful flight

#### ε **Mission 3 - Medical Supply Mission**

- 3 Lap payload flight
- Payload will be team selected quantity of golf balls. Teams will specify the number of balls they will fly when entering the staging box and will load the balls as part of the aircraft assembly and checkout (timed) prior to going to the flight line.
- Mission score  $M3 = 2 \times N\_balls / N\_max$ .  $N\_max$  will be the maximum number of golf balls flown by any team getting a successful score for this mission.

### Flight Line Order:

- ε A **flight order** list will be generated and **emailed to the teams on the Wednesday prior to the fly-off weekend**. Teams will always rotate in this order. The flight order will be repeated continuously.
  - The flight order list will carry over from Saturday to Sunday at what ever spot in the rotation it leaves off.
  - Each team's position in the flight order will be determined from their written report score, highest report score goes first.
  - Report scores will be available following the pilot briefing at the start of the contest (they will not be included with the rotation sequence e-mail).
- ε There will be four **staging box** positions near the flight line.
- ε If you are not ready to enter a **staging box** when your rotation number comes up you will miss your opportunity for that rotation.  
**Note:** We will not call teams to the **staging box**, it is the teams responsibility to monitor the progress of the contest and decide when they need to be ready to enter an open spot in the **staging box**. A contest official will be available to help teams in entering the **staging box**.
- ε Electing to enter one of the **staging box** positions on your turn in the rotation order **will constitute using a flight attempt**.  
 If you choose to leave the **staging box** for any reason you will **forfeit that flight attempt**.  
 If you go to the flight line and are not able to begin your flight when instructed you will **forfeit that flight attempt**.

### General Mission Specification and Notes:

- ε The aircraft propulsion system(s) must be "safed" (fuse removed) during any time when crew members are preparing/handling the aircraft **except during the hand launch**.
- ε Maximum flight support crew is: **pilot, observer, and 1 ground crew (for 2010/11 contest)**. Only the designated ground crew may load the aircraft payload.
- ε Observer and all ground crew must be students. **Only the pilot may be a non-student**.
- ε The upwind turn will be made after passing the upwind marker. The downwind turn will be made after passing the downwind marker. Upwind and downwind markers will be 500 ft from the starting line. Aircraft must be "straight and level" when passing the turn marker before initiating a turn.



- ε Aircraft must land on the paved portion of the runway. Aircraft may "run-off" the runway during roll-out. Aircraft may not "bounce" off the runway.
- ε *Aircraft obtaining "significant" damage during landing will not receive a score for that flight. Determination of "significant" is solely at the discretion of the Flight Line Judge.*
- ε Flight altitude must be sufficient for safe terrain clearance and low enough to maintain good visual contact with the aircraft. Decisions on safe flight altitude will be at the discretion of the Flight Line Judge and all rulings will be final.

Additional information is included in the [FAQ](#) (Frequently Asked Questions).

## Flight Course:

The orientation (direction) of the flight course will be adjusted based on the prevailing winds as determined by the Flight Line Judge. The flight course will be positioned to maintain the greatest possible safety to personnel and facilities. The nominal flight course is shown in the Figure below.

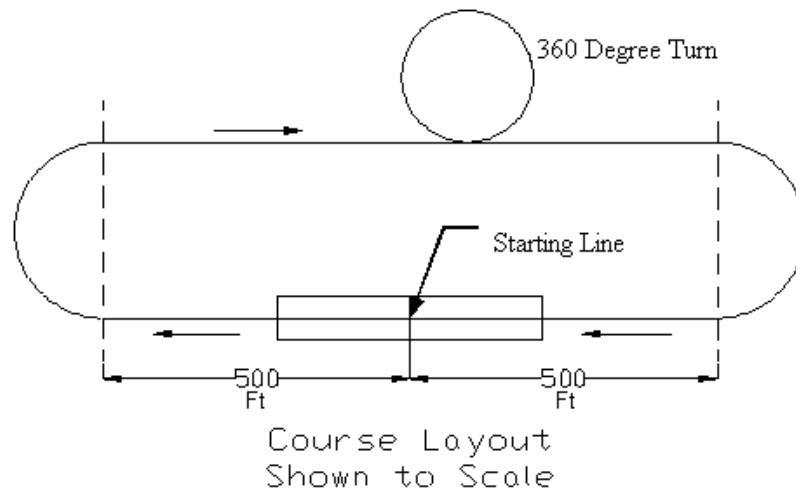

## Protest Procedure:

Submitting a protest is a serious matter and will be treated as such. Teams may submit a protest to the Contest Administration at any time during the competition. Protests may not be submitted after the conclusion of the competition. Protests must be submitted in writing and signed by the team advisor, designees are not allowed for protest submissions. If the team advisor is not present, he may FAX a signed protest to the team for them to present. Protests may be posted for review at the decision of the administration.

Protests and penalties (up to disqualification from the contest for deliberate attempts to misinform officials, violate the contest rules, or safety infractions) will be decided by the Contest Administration. **Protests submitted but not upheld by the judges *may* be given a penalty of the loss of one flight score to the team submitting the protest.** The decision of the Contest Administration is final.

## Design Report:

Each team will submit a judged design report as outlined below and in the **SCHEDULE** section above.

**Note: Reports must strictly adhere to the following requirements. Failure to meet requirements will result penalties that range from score reduction to elimination from the contest.**

- ε Reports must have the University and Team name (as listed on the ORIGINAL entry form, not team

“nicknames”) on the cover page.

*Reports missing this identification information will not be scored.*

- ε Reports must be bound. Simple spiral bindings are sufficient and preferred. Paper clips, 3-ring binders, or clamps are **NOT allowed**.

Stapled reports will be *penalized 10 points*

*Unbound reports will not be scored.*

- ε Report paper may be no larger than 8 ½ inches wide by 11 inches long with the exception of the drawing package.

A4 paper may be used **ONLY** if it is cut to a maximum length of 11 inches.

The drawing package may be on 11 inch long x maximum of 17 inch wide pages.

*A 10 point penalty will be given for the use of oversize paper.*

- ε Absolute maximum page count for the report is **60 pages**, inclusive of all pages of any type including any form of front and back cover.

For reports printed as double sided, blank back-sides of pages **WILL** be included in the page count with the specific exceptions of:

- 1) the back side of the very first page or cover;
- 2) the back side of the very last page or cover;
- 3) the back side of 11 inch x 17 inch size drawing pages.

*Reports exceeding the maximum page count will be given a 10 point penalty for each additional page.*

- ε Reports will be scored on a 100 point basis following the guidelines outlined below.
  - All information used for scoring **must be in the outlined sections, content that is out of sequence, including the drawing package, will be treated as missing** and scored accordingly.
- ε All reports should be at least one and one half line spacing, 10-pt Arial font. Tables and figures will also be at least 10-pt Arial font. Margins should be at least 1 inch on all sides. All figures and tables should be clear and readable for the judges. The reports will be judged on format and readability.
- ε **ALL** items requested below should be present, easy to locate and identify, well documented and in the correct section for full scoring.
- ε Examples of winning team design reports from prior contest years are posted on the contest website. Note that the formatting and content has changed from one year to the next. Prior year reports may not reflect or meet the rules listed for the current year.

### Note:

*Protective pages (clear or otherwise) are not required and are a waste of money.*

*Reports are very durable. Please ship in envelopes. Boxes and bubble wrap are not required. We're going to ship them to the judges in envelopes. You won't be penalized if the shipper tears a cover. Remember. We throw them away when we're done.*

*Do Not Use Styrofoam Peanuts!!!*

*Do not ask for confirmation of receipt. Documentation to prove that your reports were shipped with guaranteed delivery by the deadline and proof that your email was sent well before the deadline are all that's required to prevent disqualification.*

**Report scoring is based on the reports AS SUBMITTED. Final proofing of the report printed copies (ALL) prior to submission is STRONGLY encouraged.**

## Design Report

All section scores will include format, completeness and readability

1. Executive Summary: (10 points):
  - ... Provide a summary description of your selected design and why it is the best solution to the specified mission requirements.
  - ... Describe your key mission requirements and design features keyed to those requirements.
  - ... Document the performance/capabilities of your system solution.

2. Management Summary (5 points):
  - ... Describe the organization of the design team.
  - ... Provide a chart of design personnel and assignment areas.
  - ... Provide a milestone chart showing planned and actual timing of the design / fabrication / testing processes.
3. Conceptual Design (15 points):
  - ... Describe mission requirements (problem statement).
  - ... Translate mission requirements into design requirements.
  - ... Review solution concepts/configurations considered.
  - ... Describe concept weighting, selection process and results.
4. Preliminary Design (20 points):
  - ... Describe design/analysis methodology
  - ... Document design/sizing trades
  - ... Describe/document mission model (capabilities and uncertainties)
  - ... Provide estimates of the aircraft lift, drag and stability characteristics.
  - ... Provide estimates of the aircraft mission performance.
5. Detail Design (30 points total. 15 points for discussion items, 15 points for drawing package):
  - ... Document dimensional parameters of final design.
  - ... Document structural characteristics/capabilities of final design.
  - ... Document systems and sub-systems design/component selection/integration/architecture.
  - ... Document Weight and Balance for final design. Must include a Weight & Balance table for the empty aircraft and with each of the possible payloads
  - ... Document **flight** performance parameters for final design.
  - ... Document **mission** performance for final design.

Drawing Package

  - ... 3-View drawing with dimensions.
  - ... Structural arrangement drawing.
  - ... Systems layout/location drawing.
  - ... Payload(s) accommodation drawing(s).
6. Manufacturing Plan and processes (5 points):
  - ... Document the process selected for manufacture of major components and assemblies of the final design.
  - ... Detail the manufacturing processes investigated and the selection process/results.
  - ... Include a manufacturing milestone chart showing scheduled and actual event timings.
7. Testing Plan (5 points):
  - ... Detail testing objectives, schedules, and check-lists.
8. Performance Results (10 points):
  - ... Describe the **demonstrated** performance of key subsystems and compare it to predictions from Section 5. Explain any differences and improvements made.
  - ... Describe the **demonstrated** performance of your complete aircraft solution and compare it to predictions from Section 5. Explain any differences and improvements made.

## Design Report Electronic Copy

Each team must provide an electronic copy of their final design report in addition to the hard copies used for the report judging as outlined below.

- ε Electronic copy must be **RECEIVED** by the same deadline as listed above for the written reports.
- ε Electronic report files must be named: “**2011DBF** *[university]* *[team name]*.PDF”
- ε Electronic report must be a single file with all figures/drawings included in the proper report

sequence in PDF format.

(Free PDF file conversion programs are available on the Internet, such as [www.pdf995.com](http://www.pdf995.com).)

- ε Electronic reports should have all figures compressed to print resolution to minimize file size.
- ε Electronic reports must be less than **20 MB** in size (including encoding for e-mail transmission) and e-mailed to: [designbuildfly@gmail.com](mailto:designbuildfly@gmail.com).

---

[\[AIAA Student Design/Build/Fly Competition homepage\]](#) [\[AIAA Homepage\]](#)

4Sep2010 Update



### Frequently Asked Questions (FAQ)

**Please check the FAQ often during the competition. Please note that rules interpretation questions are not answered by e-mail until after the end date (when all participant e-mail address are known), so that all teams will have equal access to all rules information.**

**\*\*\* All Rulings In This FAQ Supplement The Official Rules! \*\*\***

#### General Notes:

- ⌘ 2.4 GHz ISM band radios are now legal for the contest. They MUST be capable of implementing the full fail-safe sequence procedure outlined in the rules. If you are going to use a 2.4 GHz radio please note it in the appropriate location on the entry form.
- ⌘ Brushless motors are now legal.
- ⌘ Ni-mH batteries are now legal. Li-Poly batteries are NOT legal for use either as propulsion or RC batteries.

#### Flight / Mission Questions

1. **Question:** Do we have to fly all of the different missions to get a score?  
**Answer:** You will get a score for each mission you successfully complete. The flights must be completed in the order specified to obtain a score.
2. **Question:** Do we have to use the same plane for each mission?  
**Answer:** You must use a single plane for the entire contest weekend.
3. **Question:** Is it permitted to add/remove necessary/unnecessary components to/from the aircraft to perform the different flight missions?  
**Answer:** You may change internal (payload bay) components between missions. All external portions of the aircraft must remain the same for all mission.
4. **Question:** What constitutes a successful landing?  
**Answer:** The aircraft must touch down ON the runway. It may roll/slide, not bounce, off the runway after touchdown.
5. **Question:** Is there a minimum altitude for flying the course?  
**Answer:** No. Altitude must be high enough for safe flight as set by the discretion of the Contest Director.
6. **Question:** Can we tailor the configuration of the aircraft differently for the different missions? For example, could we use different sized propulsion systems for each flight?  
**Answer:** You cannot change the hardware configuration of the aircraft for the different missions. You can however change the propeller diameter/pi for each flight attempt.
7. **Question:** What would constitute "non-critical" versus "significant damage" on landing as described in the rules?  
**Answer:** The decision will be at the discretion of the flight line judges. In general, "non-critical" damage would allow the aircraft to be easily returned to safe flight status. A couple of examples of "non-critical" damage would be a broken propeller, bent landing gear, sheared nylon bolts or minor scratches to the finish. If any component is structurally damaged and would be considered a hazard to safe flight then it will be considered as "significant damage".
8. **Question:** At what wind speed will the contest be called.  
**Answer:** It will be up to each team to determine whether they want to fly or not. The contest will be called if the wind speed exceeds 30 mph for a period of time sufficient to prevent all teams who are ready to fly from being assigned a flight time slot. The 30 mph limit is consistent with normal AMA competitions and is required to retain our contest insurance coverage.

#### Aircraft Configuration Questions

1. **Question:** On the webpage it states that aircraft CANNOT be of rotary wing design. Rotary wing being somewhat defined in another section as 'vertical flight capability'. However, thrust vectoring IS allowed, as are ducted-fan units. Is vertical Take-off via ducted-fan units legal, or does that fall under the rotary aircraft definition?  
**Answer:** A ducted fan configuration capable of thrust vectoring for short take-off but not true vertical flight would be legal.
2. **Questions:** Can there be thrust vectoring via rotating the engine, nozzles, blown surfaces etc.?  
**Answer:** Yes. Any of the above options is allowed, and may be varied during flight. However, "rotary wing" vehicles are not allowed, so you may need to consult the judges with your specific design doesn't cross over the line into vertical flight capability.
3. **Question:** We have talked with an outside vendor and they possess a *manufacturing* technique that we are not capable of producing here at the school. The design of the part would be done by us, with *manufacturing* done by them.. Is this permitted by the rules?  
**Answer:** No. The rules (sponsor section) say "All design, analysis and fabrication of the contest entry is the sole responsibility of the student team members." Commercial components may be used if part of the manufacturer's public product line.
4. **Question:** Our team has completed our design calculations and we have found a manufacturer that carries wing *components* that will meet our design criteria. Can we purchase *components* (i.e. foam cores and skins) to construct the wing for our UAV, or are we required to build it from scratch? If our school does not have machining capabilities can we have a vendor laser cut our ribs and formers or machine our original design molds?  
**Answer:** You may use *unassembled components* such as wing cores providing they are integrated in a way that results in the final configuration being an original design. You may also have *components* of your design machined to your design specifications by an outside contractor if the team and/or university does not have the required machining facilities. You may have molds machined for composite parts, but the team must make the actual parts themselves.

5. **Question:** Are gyros legal for stability purposes?  
**Answer:** Yes
6. **Question:** Do the external fuse accessibility requirements (from behind if tractor, from the front if pusher) exclude the use of a pusher-puller type mu engine configuration?  
**Answer:** You may use a push-pull configuration but must locate the fuse(s) such that they can be accessed by the crew member without having to rea over or around either propeller or being in the propeller disk plane of either propeller.
7. **Question:** Does the propulsion battery have to be a single unit (with all cells physically and electrically connected) or can it consist of separate packs  
**Answer:** You may use multiple battery "packs" to power either multiple or a single motor(s) provided the total weight of all packs flown as a set mee the rules requirement. Any/all packs/motors must be fused such that no single battery or motor can exceed the maximum current requirement. If it requires multiple fuses to meet the current protection requirement, then **ALL** fuses must be removed whenever you are required to "safe" the aircraft system.
8. **Question:** When you check the CG, what kind of a point will you use? For example will it be checked with fingers or dowels or something even sharper?  
**Answer:** The CG check will be coincident with the structural verification test described in the Safety Requirements supplement to the basic rules. Specifically, two team members will be asked to pick the aircraft up by the wing tips using their hands (usually a clenched fist placed under the wing the desired location works well). They will (gently) lift the aircraft at it's full contest weight by the wing tips at the marked axial CG location. For airc configurations where the CG is not within the chord of the wing tips, a third lift point, located as far from the CG as possible, will be used to balance aircraft.

### Report Questions

Report rules may be changed from prior years. Be sure to follow the current rules. Being allowed in prior years is not grounds for expecting the same i to be allowed this year.

### General Questions

1. **Question:** Is it safe to assume that if the rules do not explicitly forbid something, it is allowed?  
**Answer:** The rules are intentionally designed to not impose too many limitations while allowing each team an equal chance. If something adheres to "spirit" of the rules it is likely to be allowed. **If you have any specific questions you would like clarified** they may be addressed in a private e-mail to the contest administrator. Ideas will not be disclosed to other teams if they represent a legal and innovative approach. If it is deemed to be not legal, it may be added to this FAQ or posted to the other teams at the administrator's discretion.
2. **Question:** Regarding the test flight photo, does this photo have to be submitted with the report, or just brought to the competition?  
**Answer:** The photo must be shown to the judges during the technical inspection. We will not have copies of the reports available at the contest, so if you want to use a photo in your report you must bring your own copy.
3. **Question:** Can we use LiPo batteries in our transmitter?  
**Answer:** No.
4. **Question:** Are the transmitter and receiver allowed to be store bought?  
**Answer:** The transmitter and receiver **MUST** be a commercial FCC approved system. No modifications to the transmitter (or it's case) or the receive (or it's case) are allowed.
5. **Question:** Do all of the team members need to be student members of AIAA?  
**Answer:** Since the DBF is part of the AIAA competitions sanctioned by the Student Activities Committee and the AIAA Foundation, all team memb should be student members of the AIAA.
6. **Question:** What was the maximum number of people that can make-up a team.  
**Answer:** There is no specific limit on team size. It is up to the team itself to determine a size sufficient to meet the required tasks and small enough to remain manageable. It is expected most teams would fall in the 5 to 10 member size range, but this is only an estimated guideline. There is a maximum size of the flight crew (pilot and assistant) and ground crew. Please see the CURRENT YEAR RULES for more details on the limitations on the flight and ground crews.
7. **Question:** Is it necessary to list all team members on the entry.  
**Answer:** Yes, we need to know all the team members to verify the under/upper classmen rule.
8. **Question:** What is meant by "Upper and Under Classmen"  
**Answer:** Upper Classmen are (for purposes of the contest) seniors and/or graduate students. Lower Classmen are Freshmen, Sophomores and Juniors
9. **Question:** Does the 1/3 under classmen rule apply to the people present at the fly-off site?  
**Answer:** No. The 1/3 , 2/3 distribution applies to the team as a whole, from the entry date through the end of the contest. Not all team members mus present at the fly-off.
10. **Question:** Is it allowed to have/declare more then 1 pilot in a team (in case one of them can not go to the contest, or simply have a back-up pilot)?  
**Answer:** Yes, teams may register multiple pilots as long as each meets the requirements listed in the rules.
11. **Question:** Can the team members be changed?  
**Answer:** Team members may be updated/changed at any time during the contest provided the required team makeup is maintained. We will make a "One Time" update to the posted team member lists posted on the website. Teams wishing a team member list update must submit an updated copy the contest entry form with all fields fully filled (but only the team member names may be changed) between 1 Feb and 15 Feb.
12. **Question:** Can we have corporate sponsors? If so, can we put their logo on the UAV at any place that pleases them?  
**Answer:** Teams may solicit and accept sponsorship in the form of funds or materials and components from commercial organizations. All design, analysis and fabrication of the contest entry is the sole responsibility of the team members. Sponsor and university decals or logos may be placed as desired. Teams should make sure that the final color scheme of the aircraft provides good visibility of the aircraft location and orientation for the pilot.
13. **Question:** How is the radio fail-safe described in the safety supplement to be implemented.  
**Answer:** This is a feature available in many production RC radio systems. It is **required** that your radio system be able to provide this function.

[\[Top\]](#) [\[AIAA Student Design/Build/Fly Competition homepage\]](#) [\[AIAA Homepage\]](#)