

1998/99 Rules and Vehicle Design Specification

Judging:

For the 1998/99 contest year aircraft will be designed to carry the most payload possible using multiple sorties within a 10 minute competition period.

Each team must also submit a written Design Report, which is divided into two phases as noted in the documentation requirements section. A maximum of 100 points will be awarded for the team design report. (One score will be given accounting for both sections.) Scores for the written reports will be announced at the beginning of the fly-off.

The overall ranking will be a combination of the paper score and flight score. The team with the highest overall ranking will be declared the winner.

Contest Site:

Host for the competition will be the Office of Naval Research. The fly-off will be held at Webster Field, a component of the Naval Flight Test Center at Patuxent Maryland.

Team Requirements:

All team members (except for a pre-approved designated pilot) must be full time students at an accredited University or College. The team must be composed of both under classmen and upper classmen, with at least 1/2 of the members being under classmen (Freshman, Sophomores or Juniors). The pilot must be an AMA (Academy of Model Aeronautics) member. Teams may use a non-university member for the pilot if desired. Such a designated pilot must be from the local area, and pre-approved by the contest officials. We will also provide qualified pilots on the contest day for any teams who are unable to have their pilot attend.

Technical Assistance:

A non-exclusive list of some available suppliers for materials, R/C systems, electric motors and NiCad batteries is included at the contest web [site](#).

Past Reports:

A compendium of the entry technical reports from prior-year competitions is published by ONR through the NTIS. Individual entry reports are also available by request from the AIAA. All reports submitted become the property of [AIAA](#), [ONR](#), and [Cessna](#)

Preferred access to the prior-year reports is through NTIS, However, individual reports may also be requested from AIAA (AIAA policy is to make all student competition reports available). Teams outside the US may not have access to the NTIS reports, so may need to contact AIAA for copies.

1996/97 Report:

2031840 NTIS Accession Number: AD-A329 477/4/XAB
Support of AIAA Student Aircraft Design/Fly Competition
(Final rept. 1 Apr-31 Dec 97)

Sponsorship:

Teams may solicit and accept sponsorship in the form of funds or materials and components from commercial organizations. All design, analysis and fabrication of the contest entry is the sole responsibility of the team members.

Schedule:

A completed entry form (electronic) is due to the contest administrator on or before **31 October 1998**. Written reports for the **PROPOSAL PHASE** (5 copies), are due to the contest administrator by **COB 15 March 1999**. Written reports for the **ADDENDUM PHASE** (5 copies), are due to the contest administrator by **COB 5 April 1999**. Scores for the written reports will be announced at the beginning of the fly-off. The contest is scheduled for **24-25 April 1999**.

Late submissions will not be judged. Teams who do not submit the required written reports will not be allowed to fly.

Communications:

The contest administration will maintain a World Wide Web site containing the latest information regarding the contest schedules, rules, and participating teams. The contest web site will also contain a list of potential suppliers for materials and equipment required to build an entry. The contest web site is located at:

<http://www.aae.uiuc.edu/aiaadbff>

All teams are required to provide a single point-of-contact e-mail address with their contest application.

Questions regarding the contest, schedules, or rules interpretation may be sent to the contest administrator by e-mail at:

gregory.s.page@nrl.navy.mil

Copies of all questions received and their answers will be provided to all teams of record by the contest administrator.

New for this year, entries will be submitted electronically. Teams may download the MS-WORD entry form from the contest web site, and e-mail them as an attached file to the contest administrator.

Written reports should be sent to the contest administrator by mail or express delivery at:

AIAA Design/Build/Fly Contest
Gregory S. Page / Bldg 210
Kaman Sciences Corporation
2560 Huntington Avenue
Alexandria, VA 22303

Aircraft Requirements - General

- ε The aircraft may be of any size and configuration except rotary wing or lighter-than-air.
- ε Wing Span must be less than or equal to 9 feet.
- ε Must be propeller driven and electric powered with an unmodified, over the counter model aircraft electric motor. May use multiple motors and/or propellers. May be direct drive or with gear or belt reduction. For safety, each aircraft will use a commercially produced propeller. Teams may modify the propeller diameter by clipping the tip.
- ε Must use over the counter NiCad batteries. For safety, battery packs must have shrink-wrap or other protection over all electrical contact points. The individual cells must be commercially available, and the manufacturers label must be readable (i.e. clear shrink wrap preferred).
- ε Aircraft and pilot must be AMA legal. This means that the aircraft TOGW (take-off gross weight with payload) must be less than 55 lb., and the pilot must be a member of the AMA. Since this is an AMA sanctioned event, the team must submit proof that the aircraft has been flown prior to the contest date (in flight photo or video).

The pilot need not be a student at the represented university. Application for approval of a non-student pilot must be presented to the contest administrator for approval at least one month prior to the written report, PROPOSAL PHASE submission.

Aircraft Requirements - Safety

All vehicles will undergo a safety inspection by a designated contest safety inspector prior to being allowed to make any competition or non-competition (i.e. practice) flight. All decisions of the safety inspector are final. Safety inspections will include the following as a minimum.

1. Physical inspection of vehicle to insure structural integrity.
 - Verify all components adequately secured to vehicle. Verify all fasteners tight and have either safety wire, lock-tite (fluid) or nylock nuts.
 - Verify propeller structural and attachment integrity.
 - Visual inspection of all electronic wiring to assure adequate wire gauges and connectors in use. Teams must notify inspector of expected maximum current draw for the propulsion system.
 - Radio range check, motor off and motor on.
 - Verify all controls move in the proper sense.
 - Check general integrity of the payload system.
2. Structural verification. All aircraft will be lifted with one lift point at each wing tip to verify adequate wing strength (this is equivalent to a 2.5g load case) and to check for vehicle cg location. Teams must mark the expected empty and with payload cg location on the exterior of the aircraft fuselage. Special provisions will be made at the time of the contest for aircraft whose cg does not fall within the wing tip chord. This test will be made with the aircraft filled to it's maximum payload capacity (Teams must inform the inspectors and judges of their maximum design capacity, and must make all flights within that capacity).
3. Radio fail-safe check. All aircraft radios must have a fail-safe mode that is automatically selected during loss of transmit signal. The fail-safe will be demonstrated on the ground by switching off the transmit radio. During fail safe the aircraft receiver must select:
 - Throttle closed
 - Full up elevator
 - Full right rudder
 - Full left aileron
 - Full Flaps down (if so equipped)
4. All aircraft must have a mechanical motor arming system separate from the onboard radio Rx switch. This may be a mechanical switch rated for the maximum current draw accessible from

outside the aircraft, or can be a removable link such as an automotive "blade" style fuse. The aircraft Rx should always be powered on and the Tx throttle verified to be "closed" before activating the motor arming switch.

Mission Profile:

The mission objective is to carry the greatest payload possible over a specified course using multiple sorties. Each aircraft will have a minimum payload capacity, there is no maximum payload capacity specified. Teams may choose to fly less than the maximum capacity of their aircraft on any sortie. This will allow teams to optimize their design for payload capacity and time per sortie, and to adjust their mission profile based on prevailing weather conditions. Since the mission encourages multiple sorties, ground handling, take-off and landing are paramount design considerations.

- ε Each sortie will consist of a take-off, one downwind leg, and a landing. Teams will fly as many sorties as possible with a 10 minute competition period. The time to unload and reload the payload for the next sortie is part of the competition period.
- ε Aircraft will be brought to the flight line to begin the competition period with the payload for the first sortie already loaded. Teams will be given a maximum of 2 minutes to place their aircraft on the starting line and prepare for competition before the judges start the timed competition period. They will then have 10 minutes to complete as many sorties (flights) as possible.
- ε The aircraft payload must be emptied and reloaded before each additional sortie.
- ε Maximum flight support crew is: pilot, observer and 3 ground crew. Only the designated ground crew may conduct the unloading/reloading. Pilot and observer may be members of the ground crew, provided total ground crew size remains 3 people.
- ε The payload will be water contained in removable round or square polyethylene bottles. Payload may be made up of any possible combination of 500ml, 1000ml, and 2000ml bottles desired. Each aircraft must have a capacity of at least 2 liters which will be verified during the technical inspection. There is no maximum payload limit. Payload may not be carried in the outer 1/2 span of the wing.

Suitable bottles can be obtained from McMaster Carr (732-329-3200) as #4577T46 (500ml); #4577T48 (1000ml); and #4577T21 (2000ml). Other equivalent bottles are allowed.

- ε Teams may fly any amount of payload desired on each sortie, either by combinations of bottles or by partially filling bottles (though provisions must be made for partial bottles to prevent "slosh").

Each sortie must have "new" bottles, so teams should prepare to have sufficient payload available. Total payload flown will be weighed at the end of the 10 minute competition period.

- ε Teams will be scored on the total weight of payload (water plus bottle) flown during a single 10 minute competition period.

SCORE = Written Score * Weight Carried

- ε Take-off must have wheels off the ground within 100 feet of the starting line.
- ε The upwind turn will be made after passing the upwind pylon. The downwind turn will be made after passing the downwind pylon. Upwind and downwind pylons will be 500 Feet from the starting line. Aircraft must be "straight and level" when passing the pylon before initiating the turn.
- ε Aircraft must complete either a right or left 360 degree turn on the downwind leg of each sortie. The direction will be specified on the contest day and will be opposite to the direction of the flight pattern.
- ε Aircraft must land on the paved portion of the runway. Aircraft may "run-off" the runway during

roll-out.

- ε After landing, aircraft will taxi back to the starting line to unload their payload, and reload for the next sortie. Wing-Walkers are allowed to accompany the plane during the taxi, but must wait at the starting line until the aircraft comes to a complete stop before going to assist the aircraft. Sorties may be repeated as many times as possible provided the aircraft has passed the downwind turn pylon before the time limit for the competition period expires.
- ε Aircraft that run off the runway during landing may be carried back to the runway by the ground crew to taxi back to the starting line. Aircraft that leave the runway will be returned to the runway at the nearest possible location
- ε Aircraft unable to taxi back to the starting line due to landing damage may be carried by the designated ground crew. Ground crew members will not be allowed to leave the starting line to retrieve the aircraft until the aircraft has stopped.
- ε Credited payload is that amount of payload successfully unloaded at the end of each sortie. Payload not physically attached to the aircraft at the completion of landing (i.e. any payload which becomes separated from the aircraft during landing for any reason) does not count.
- ε Aircraft experiencing minor landing damage may be repaired and fly additional sorties within the competition period. Repairs must be made on the starting line, and may not begin until the payload has been unloaded. Repairs must be completed before the payload is reloaded for the next sortie. All team members may assist in repairs, only ground crew members may reload the aircraft.
- ε Aircraft will be considered to have only minor damage if they can be repaired and presented as flight worthy within 20 minutes of the end of that competition period. Aircraft with only minor damage will be credited with their full carried payload.
- ε Aircraft which can be repaired during the competition, but not within 20 minutes of the competition period, will be credited with 1/2 of their carried payload.
- ε Flight altitude must be sufficient for safe terrain clearance and low enough to maintain good visual contact with the aircraft. Decisions on safe flight altitude will be at the discretion of the flight line judges and all rulings will be final.
- ε No components may be dropped from the aircraft at any time during the flight.

Additional information is included in the FAQ (Frequently Asked Questions).

Design Report:

Each team will submit a judged design report as outlined below. The design report will be submitted in two sections. Submission dates are contained in the schedule section of this document. Reports must be bound in some manor (simple spiral bindings are sufficient and preferred, 3-ring binders are discouraged). Both the Proposal and Addendum reports must contain the same cover, title page, and table of contents. All information used for scoring must be in the outlined sections. Appendices may be included if desired, but WILL NOT BE INCLUDED DURING JUDGING.

Design Report-PROPOSAL PHASE

1. **Executive Summary:** (Maximum 2 pages, 5 points): Provide a summary of the development of your design. This should be a narrative description highlighting the major areas in the development process for your final configuration and a broad description of the range of design alternatives investigated. Include an overview of the design tools used for each phase of the design development: conceptual design, preliminary design, and detailed design.
2. **Management Summary** (Maximum 1 page, 5 points): Describe the architecture of the design team. Provide a list of design personnel and assignment areas. Document the management

- structures used for personnel assignments, schedule control, and configuration control. Include a (single) milestone chart showing planned and actual timing of major elements of the design process, including as a minimum the conceptual design stage, preliminary design stage, detailed design stage, and report preparation periods.
3. **Conceptual Design** (Configuration Selection, Maximum 3 pages, 10 points): Document the alternative concepts investigated during the conceptual design stage. Detail the design parameters investigated, and why each was felt to be important. Describe the figures of merit (FOMs) used to screen competing concepts, and the mission feature each FOM was selected to support. Describe the analytic methods used during the conceptual design stage, the expected accuracy and why each was selected for this design phase. Numerical data need not be extensive at this stage, but should include as a minimum a final ranking chart giving the quantitative value of each design for each FOM, the FOM importance factors or ranking, and an explanation of the features that produced the final configuration selection.
 4. **Preliminary Design** (Performance Estimation and Vehicle Sizing, Maximum 5 pages, 20 points): Document the design parameter and sizing trades investigated during the preliminary design stage. Detail the design parameters investigated, and why each was felt to be important. Describe the FOMs used and the mission or design feature each FOM supports. Describe the analytic methods used during the preliminary design stage, the expected accuracy and why each was selected for this design phase. Numerical data will be more extensive at this stage, and should include as a minimum configuration and sizing parameter values sufficient to justify the selection of the final value chosen for each of the major design and sizing parameters. Include a summary of the key features that distinguish the final configuration.
 5. **Detail Design** (Final Design, Drawings and Performance Predictions, Maximum 5 pages Plus Drawing Package, 20 points): Final performance data should be provided for the design, including take off performance, handling qualities and g load capability, range and endurance, and payload fraction. Component selection and systems architecture should be included in this section. The Drawing Package must contain as a minimum a 3-view drawing of the design in sufficient detail to indicate aircraft size and configuration, primary structure component size and location, and location of propulsion and flight control system components. Special credit will be given for innovative configurations, manufacturing processes, and airframe cost reduction methods.
 6. **Manufacturing Plan** (Materials Selection and Fabrication Processes, Maximum 5 pages, 20 points): Document the process selected for manufacture of major components and assemblies of the final design. Detail the manufacturing processes investigated, and describe the FOMs used (including but not limited to: availability, required skill levels and cost) to screen competing concepts. Describe the analytic methods (cost, skill matrix, scheduling time lines) used to select the final set of manufacturing processes. Include a manufacturing milestone chart showing scheduled event timings. Special credit will be given for innovative configurations, manufacturing processes, and airframe cost reduction methods.

Design Report-ADDENDUM PHASE

1. **Lessons Learned** (Maximum 4 pages, 20 points): Document any areas where the final contest aircraft differs from the PROPOSAL design. Also identify areas for improvement in the next design and manufacturing process implementation. Include estimates of time and cost required to implement the changes and the design or process improvement that should be realized in a second generation design approach. Include a table of "Manufacturers List Price" for all materials, components, and systems in the final design. Costs may be grouped as appropriate and need not be listed by each individual piece. Include a narrative assessment of how the actual costs compare to the expected costs used for design evaluations in sections 5 and 6 of the **PROPOSAL PHASE** report.

Notes:

Page counts do not include figures or tables. *Figures and tables should be placed at the end of the text for a given section.*

"Cost Reduction" does not mean donated materials or discounted prices from selected vendors. For cost considerations in the design selection and ranking all components and materials should be evaluated based on manufacturer list prices.

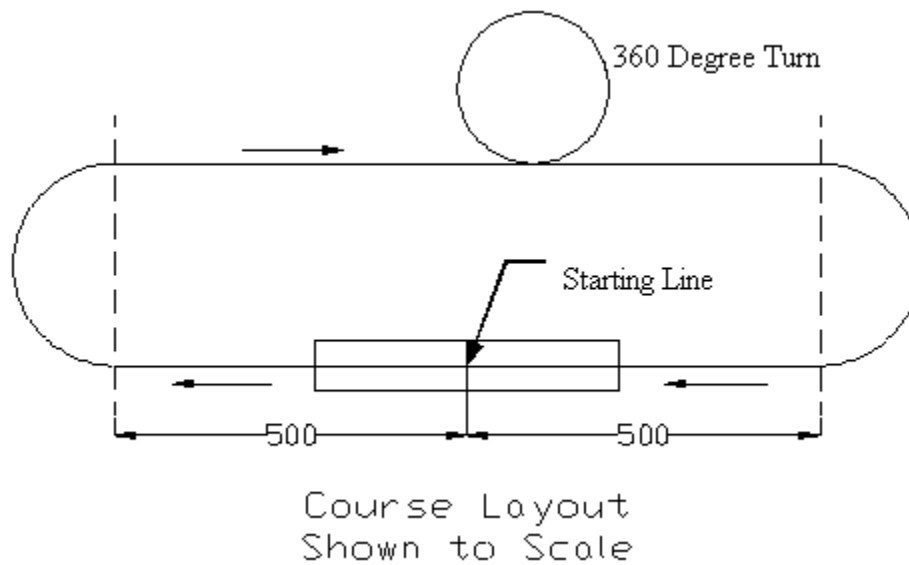

[[Top](#)] [[AIAA Student Design/Build/Fly Competition homepage](#)][[AIAA Homepage](#)]
Webmaster m-selig@uiuc.edu

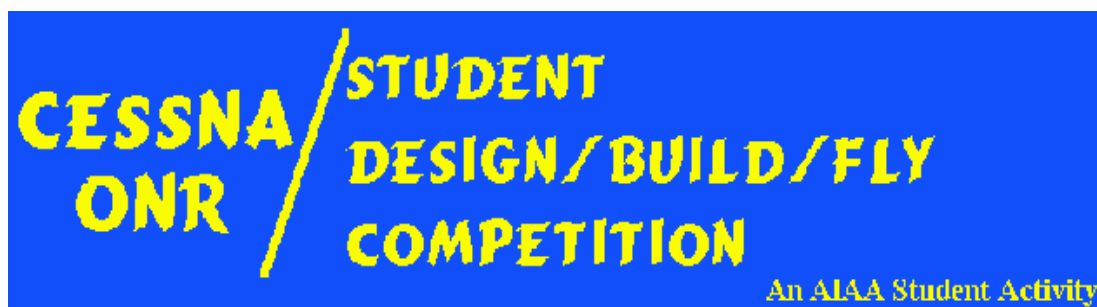

Frequently Asked Questions (FAQ)
1998/99 Competition Specific
(Updated 8 July 1998)

1. **Question:** Is there a minimum altitude for flying the course?
Answer: No.
2. **Question:** How are the turns made, and is there a set turn radius?
Answer: The turns may not be initiated until the turn judge raises his flag (for the two 180 degree turns), but may then proceed to be any turn radius and rate the aircraft is capable of. The 360 degree turn can be initiated anytime the aircraft is on the "downwind" leg and also may be any turn radius and rate the aircraft is capable of.
3. **Question:** Is it safe to assume that if the rules do not explicitly forbid something, it is allowed?
Answer: The rules are intentionally designed to not impose too many limitations while allowing each team an equal chance. If something adheres to the "spirit" of the rules it is likely to be allowed. If you have any specific questions you would like clarified they may be addressed in a private e-mail to the contest administrator. Ideas will not be disclosed to other teams if they represent a legal and innovative approach. If it is deemed to be not legal, it may be added to this FAQ or posted to the other teams at the administrators discretion.
4. **Question:** The rules state the aircraft must have the wheels off the ground in 100 feet. Is there any height requirement?
Answer: No, the rules are correct as stated. Aircraft must have **ALL** wheels off the ground by the 100 foot line, and they must remain off until the landing. There is no "obstacle" height requirement for this year.
5. **Question:** Can the battery pack be **changed out** or "**topped off**" between sorties?
Answer: No. Only payload may be unloaded and reloaded. Batteries may not be recharged.
6. **Question:** What is the penalty for not initially landing on the runway?
Answer: The site anticipated for the 98/99 competition is Webster Field. The runways are 200 feet wide and 5000 feet long. Landing on the runway should not be a problem. However, the judges will reserve the right to determine on an individual basis if the landing was a valid landing or not.
7. **Question:** If the aircraft runs off the runway but is not damaged, can the ground crew help retrieve it?
Answer: If the aircraft runs off the runway, the ground crew can go to retrieve it once it has stopped. If the aircraft is undamaged, they will return it to the runway to taxi back. If it is damaged and is unable to taxi back, the ground crew may carry it back and make repairs.
8. **Question:** Can one use standard water bottles from the store, for example an Evian bottle, as long as it is still within the 500mL, 1000mL or 2000mL category?
Answer: Most likely, no. Water bottles must be polyethylene (a milky colored fairly soft plastic), most "store" water bottles are polystyrene. Also, the 500mL, 1000mL, 2000mL are NOT ranges, they are specific sizes and only those size bottles may be used. You can not use an "intermediate" size (say 750mL) bottle to get a better payload space fit.

9. **Question:** Where must the "minor repairs" be made?

Answer: Repairs must be made on the starting line if the plane is to be eligible to make an additional sortie within the "10 minute" time period.

Repairs for the "20 minute" rule may be made at the teams pit, but must be clearly "repairs" not getting out another airplane. You can't change out the fuselage, wing or empennage with new parts, you must repair the "flown" primary airframe structure. Systems (radio, servos, propulsion) and secondary airframe structure (landing gear legs, wheels) may be replaced and qualify for the repair rule.

If the battery pack must be changed due to damage (not just out of juice), the repairs automatically fall into the ½ payload credited category.

10. **Question:** Is the weight credited as scored the same as the weight placed onboard at the beginning of the flight?

Answer: Credited payload is that amount of payload successfully unloaded at the end of the flight, not the amount loaded at the beginning of the flight. Any "payload" containers which become separated from the aircraft (such as during a hard landing) will not be included in the score for that flight. Additionally, students are reminded to make certain the payload (water) can not "leak" from the aircraft during flight. Teams must also take precautions to be sure the radio system is protected against water contact/damage during flight. A general check of tank integrity will be made during the technical inspections.

11. **Question:** What is a sortie and what is meant by multiple sorties may be flown?

Answer: For this years (98/99) competition, a "sortie" consists of (1) loading the payload; (2) take-off, downwind leg with 360 degree turn, landing, taxi back to starting line; and (3) unloading the payload. Teams may complete as many cycles of this "sortie" as possible within their given 10 minute competition time period.

12. **Question:** Can we have two or more sets of wheels which we can interchange during the competition, if the first set wears out quickly.

Answer: The rules allow "moderate" servicing between flights. You may change wheels provided you can do so within the time period for your flights.

Frequently Asked Questions (FAQ)

General

1. **Question:** Do all of the team members need to be student members of AIAA?

Answer: Since the DBF is part of the AIAA competitions sanctioned by the Student Activities Committee and the AIAA Foundation, all team members should be student members of the AIAA.

2. **Question:** What was the maximum number of people that can make-up a team.

Answer: There is no specific limit on team size. It is up to the team itself to determine a size sufficient to meet the required tasks and small enough to remain manageable. It is expected most teams would fall in the 5 to 10 member size range, but this is only an estimated guideline.

There is a maximum size of the flight crew (pilot and assistant) and ground crew (3) for this years competition. Please see the RULES section for more details on the limitations on the flight and ground crews.

3. **Question:** Is it necessary to list all team members on the entry.

Answer: Yes, we need to know all the team members to verify the under/upper classmen rule.

4. **Question:** What is meant by "Upper and Under Classmen"

Answer: Upper Classmen are (for purposes of the contest) seniors and/or graduate students. Lower Classmen are Freshmen, Sophomores and Juniors.

5. **Question:** Is it allowed to have/declare more than 1 pilot in a team (in case one of them can not go

to the contest, or simply have a back-up pilot)?

Answer: Yes, teams may register multiple pilots as long as each meets the requirements listed in the rules.

6. **Question:** Can we have corporate sponsors? If so, can we put their logo on the UAV at any place that pleases them?

Answer: Teams may solicit and accept sponsorship in the form of funds or materials and components from commercial organizations. All design, analysis and fabrication of the contest entry is the sole responsibility of the team members.

Sponsor and university decals or logos may be placed as desired. Teams should make sure that the final color scheme of the aircraft provides good visibility of the aircraft location and orientation for the pilot.

7. **Question:** What is COB in the submission dates mean?

Answer: COB - Close of Business: data must ARRIVE by 5 PM local time at the specified location.

8. **Question:** When will we receive information of the exact contest location, housing options, and the contest day schedule?

Answer: Detailed contest location and schedule information will be sent to the teams by January 1999.

9. **Question:** The contest day is graduation. Is there any possibility of moving the contest.

Answer: In selecting the contest date we have tried to minimize the conflicts with graduation, finals, mothers day,... We can't miss all possible conflicts as each university is on a slightly different schedule. Moving the date earlier would greatly increase the risk of unacceptable weather, and further shorten the time available to design and build the entries (which will seem VERY short by then).

10. **Question:** We were wondering if it wouldn't be easier to just send an official representative from the competition to our school, fly our plane, and take down the score. Then compare with all the other schools competing(they'd probably be on home turf as well), and make the final decision that way?

Answer: The single site -vs- fly-at-home issue was discussed much by the contest organizers prior to selecting the current contest structure for many of the same reasons you raised. We realize that it is difficult for students to obtain funds for fabricating an entry, even without the added costs of travel. In the end we selected the single-site format for mainly two reasons: (1) the single-site format will allow the teams to see each others entries and learn from each other and will add to the competitive fever always present when pitting your best efforts against others; and (2) the single site is the only way to assure a level playing field for all entries, as weather variations at multiple sites and days would inevitably help some entries and hinder others.

11. **Question:** At what wind speed will the contest be called.

Answer: It will be up to each team to determine whether they want to fly or not. The contest will be called (and the rain date used) if the wind speed exceeds 30 mph for a period of time sufficient to prevent all teams who are ready to fly from being assigned a flight time slot. The 30 mph limit is consistent with normal AMA competitions and is required to retain our contest insurance coverage.

12. **Question:** Will a hard runway be used?

Answer: We will select a site that provides a paved runway. Note that a "smooth" paved runway for manned aircraft may still seem "rough" for contest aircraft.

13. **Question:** Our team has completed our design calculations and we have found a manufacturer that carries wing components that will meet our design criteria. Can we purchase components (i.e. foam cores and skins) to construct the wing for our UAV, or are we required to build it from scratch?

Answer: You may use unassembled components such as wing cores providing they are integrated

in a way that results in the final configuration being an original design.

14. **Question:** Does the plane have to be an external propeller plane, or can it be a duct fan UAV?
Answer: Ducted fans are also legal if they use a commercial fan assembly.
15. **Question:** In terms of propellers. Can they be any kind of Gas engine propeller if we wish? Or do they have to be Electric motor propellers? And if we can only use electric motor propellers, can we cut them? Basically, if we wish to, can we use any kind of non-electric motor propellers if they are commercially available?
Answer: Any commercial propeller for either gas or electric models may be used. Props may be cut to reduce their diameter but the blades may not be reduced in thickness (such as by sanding the airfoils to a new profile) or in chord (such as by trimming the trailing edges).
16. **Question:** What constitutes "over the counter" batteries, and does this apply to the battery pack or to the individual cells?
Answer: The "Over the Counter" refers to the individual cells. This is a change from the rule for the 1996/97 contest year.
17. **Question:** Could the electricians in the Electronics Shop at our university build the battery pack, since they are licensed electricians?
Answer: Yes, as long as they use commercially available cells.
18. **Question:** Do you have a vendor list for speed controller and/or gear reduction suppliers?
Answer: The "MOTORS" and "ACCESSORIES" sources listed on the web site vendor page can supply controller and gearbox sources that are suited to their motors. Other sources would include all of the major hobby part suppliers listed in RC magazines.
19. **Question:** How is the radio fail-safe described in the safety supplement to be implemented.
Answer: This is a feature available in many production RC radio systems. It is ***required*** that your radio system be able to provide this function.
20. **Question:** Can we construct a composite can for an otherwise stock over the counter model motor?
 Does the motor controller have to be an over-the-counter controller?
Answer: The motor and/or controller must be an unmodified commercial product. The intent of this rule is to prevent excessive cost, and to provide all teams access to equal propulsion technology so they can concentrate on the aircraft aerodynamics and structural aspects.
21. **Question:** Do the wires and connectors have to be commercially available?
Answer: Yes
22. **Question:** When you check the CG, what kind of a point will you use? For example will it be checked with fingers or dowels or something even sharper?
Answer: The CG check will be coincident with the structural verification test described in the Safety Requirements supplement to the basic rules. Specifically, two team members will be asked to pick the aircraft up by the wing tips using their hands (usually a clenched fist placed under the wing at the desired location works well). They will (gently) lift the aircraft at it's full contest weight by the wing tips at the marked axial CG location.
23. **Question:** Will the payload be supplied by the team or the contest administration?
Answer: By the team.
24. **Question:** If battery power fails can an immediate landing be made without making a complete lap (question paraphrased by editor)
Answer: First priority is safety of personnel, followed by minimizing damage to equipment. If power fails unexpectedly the pilot will setup for as safe an emergency landing as possible. If the plane does not pass the downwind pylon that sortie's payload will not count, but any prior sorties will still be credited toward the overall score.
25. **Question:** Will there be a maximum altitude, other than the visibility requirement?
Answer: There is no specific numerical altitude limit. It would be very difficult to enforce a rigorous altitude limit without altitude telemetry equipment on each aircraft which would be a significant expense burden. The contest flight judge will enforce maintaining a "safe" altitude for

both personnel/ground and flight visibility reasons, and may order the pilot to descend if he feels the altitude is too high. In general, altitudes of 300 to 500 feet are probably nominal, and altitudes near 1000 feet are likely to have the judge order a decent.

26. **Question:** Is information available about previous year designs and results?

Answer: A summary of characteristics for all the entries that competed in the last years contest will be available on the contest web site. Remember that the objective of the prior years contest was slightly different, so you will have to adapt the design data accordingly. (Prior year rules will also be maintained on the web site for reference.)

27. **Question:** Would we ever have to make any vertical loops with the UAV?

Answer: No

[[Top](#)] [[AIAA Student Design/Build/Fly Competition homepage](#)][[AIAA Homepage](#)]

Webmaster m-selig@uiuc.edu